

Quartzia Countertop

Installation Instructions and Item Information



Contents:

Levantina Vanity Top Installation Instructions	2
Levantina Countertop Blanks	15
NSF/ANSI Standard 51 – Food Equipment Material	24
ASTM E84-10b – Test for Surface Burning	28
Seam-It Solid Surface Glue Technical Data	37
Seam-It Glue Color Matching Chart for Levantina.....	39
Seam-It Material Safety Data Sheet	40
Seam-It Applicator Gun	42
Chem-Set Silicone Properties	43
Chem-Set Silicone Material Safety Data Sheet	44

QUARTZ

Besides its natural depth of color, **QUARTZIA® By Levantina** has unparalleled durability and strength. The only natural minerals harder than quartz are diamond, sapphire and topaz

RELIABILITY

QUARTZIA® By Levantina is a hard, dense and non-porous material that is consistent throughout its composition, making it more reliable than any other natural stone

WARRANTY

QUARTZIA® By Levantina offers a 10 limited warranty

SCRATCH-RESISTANCE

Common household accidents such as a dropped knife, a fallen piece of glass or errant scissors will not scratch **QUARTZIA® By Levantina** because only materials as hard as, or harder than **QUARTZIA® By Levantina** will scratch it. Beware: no surface is indestructible.

STAIN-RESISTANCE

Because **QUARTZIA® By Levantina** is non-porous, most spills stay on the surface and are easy to clean with soapy water or a mild household cleaners

CARE AND MAINTENANCE

QUARTZIA® By Levantina is virtually maintenance-free. It does not need to be sealed and cleaning is a cinch. Simply wipe the surface with soap and water on a regular basis to maintain its beauty and shine for years to come.

DIFFICULT SPILLS

To remove difficult spills, soak the area for 10 minutes with a mild household cleaner (such as Formula 409®, Lysol®, or Windex®) then rinse and clean away with a soft Scotch Brite® pad. For stains that harden as they dry, such as food and gum, remove by gently scraping off of the surface (using a blade or putty remover) and then clean using warm water and soap

Dimensions, Thicknesses

QUARTZIA® is available in large slabs measuring 3050mm x 1400mm (120" x 55") in the thickness of 20mm ($\frac{3}{4}$ "), 30mm (1 $\frac{1}{4}$ ")

Applications

QUARTZIA® can be used in various applications due to its characteristics and dimensions. Due to its aesthetics, quality and durability it can be used for kitchen countertops, bar tops, laboratory tops, bathroom vanities, bathroom partitions, tub and shower surrounds, stair treads, walls, furniture tops, back splashes and also wherever high quality, sanitary and maintenance-free flooring or tops are required. The uniformity of coloring permits additional, coordinated applications.

Table tops, Kitchen and Bar Counters, Vanity Tops

Kitchen and bar counters, vanity tops, table tops for corporate offices, hotels, shops, supermarket, banks, airports, etc., are required to strong, durable and at the same time, be highly decorative. **QUARTZIA®** Natural Quartz surface responds to this dual function of resistance and decoration.

QUARTZIA® can be cut and installed to meet design requirements, with precision, uniformity and consistency, using special tools made for quartz surfaces

Pre – Installation procedures and basic requirements

Our goal is to provide you with the necessary tools and knowledge in order to carry out the tasks correctly and achieve customer satisfaction. Before you begin with Installation, it is important to check basic but important points. For your ready reference we have compiled them as under:

On reaching the site, ensure the access and power availability.

Unwrap all parts and check for any transportation damage.

Check for any dust or other traces in the surrounding and in the work place to avoid any contamination.

Check the fabricated pieces for any cracks, chips or voids, or any other defects, in a well-lighted area.

Check the color of the pieces by visual inspection.

Check the edges and other specifications as per the drawings.

Check if material available is correct in terms of quantity and dimensions.

Check if all the tools required for installation are available.

Always place the pieces face to face and back to back.

Avoid contact of pieces with any abrasive surface.

Use "A" frames for transporting the slabs. Do not transport slabs horizontally.

Required tools

Heavy duty electric/pneumatic angle grinder for cutting or grinding (variable speed preferred)

Light electric/pneumatic angle grinder for polishing (variable speed preferred)

Electric hand drill (variable speed preferred)

Diamond cutting disks in various sizes

Diamond contour blades

Diamond cup drills in various diameters

Diamond grinding wheel

Shaped grinding Wheel

Grinding stone

Seaming clamps

Sets of diamond and sanding polishing pads

Scraper and spatula

Engineer's square set

Angle measuring devices

Polishing bobs

Carbide-tipped drill bits

Wet edge profiling machine (edge router)

Storage racks or A-frame

Clamps in various sizes

Accessories

Pigments

Cleaning materials

Quartz granules

Adhesives

To join two pieces of **QUARTZIA®**, use polyester resin adhesive or epoxy-modified acrylic.

Adding transparent adhesive to the color-matched adhesive may improve its properties.

To join **QUARTZIA®** surfaces to a different material, use a flexible adhesive such as 100% silicone or polyurethane-based adhesives suitable for both **QUARTZIA®** surfaces and the material to which it is joined.

Use only neutral silicone with acid-sensitive substrates, e.g., metal or concrete.

The color of the adhesive used must match the color of the surface in order to achieve a minimally visible seam. If a pre-colored matching adhesive is not available, mix color paste pigments with the adhesive to achieve a match.

When mixing the adhesive to color match the surface, take into account that the color will be slightly lighter after drying.

General Safety Procedures

Maintain a clean and neat working environment. Cluttered areas invite accidents.

Keep working areas dry, well ventilated and well lit.

Keep children and visitors at a safe distance from the work area.

Do not overreach. Keep proper footing and balance at all times.

Maintain a fully equipped first-aid kit on site.

Read the instruction manuals pertaining to the tools used. Learn the tools' application, maintenance, limitations and potential hazards.

Use the appropriate tools. Do not use tools or attachments for functions or at speeds for which they were not designed. Do not use improvised tools.

Maintain tools in top condition. Keep tools sharp and clean for best and safest performance.

All electrical tools must be equipped with a Ground Fault Circuit Interrupter (GFCI). Three-prong plugs must be plugged into three-hole electrical sockets. If an adapter is used to accommodate a two-prong socket, the adapter plug must be attached to a known ground. Never remove the third prong.

Use clamps or a vise to secure work when necessary, freeing both hands to safely operate tools.

Always remove keys and wrenches. Check that keys and adjusting wrenches are removed before switching on the tool.

Do not wear loose clothing, neckties, rings, bracelets or other jewelry that may get caught in moving parts.

Wear the following protective apparel when fabricating QUARTZIA® surfaces:

Hair covering to contain long hair

Safety helmet when handling and transporting

Dust mask

Nonslip, steel-capped safety shoes

Safety glasses or other approved eye protection

Earplugs when working in noisy areas

Gloves for protection against chemicals or rough material

In wet areas, aprons and steel-capped rubber boots in addition to the above QUARTZIA® slabs and products are not hazardous as shipped and used by the end customer. However, QUARTZIA® slabs contain crystalline silica (quartz), and their fabrication and processing (i.e., cutting, sawing, grinding, breaking, crushing, drilling, sanding or sculpting) generate dust.

Unprotected and uncontrolled exposure to such dust is dangerous to health and can cause severe illnesses, such as: silicosis, lung cancer, fibrosis of the lungs, tuberculosis, kidney diseases, abrasion of the cornea, and irritation of the skin and eyes. Preexisting physical disorders may aggravate the adverse effects of exposure to silica dust.

If irritation of the eyes or skin is experienced, flush the area immediately with plenty of water. If breathing difficulties are experienced, move outdoors into fresh air. In any event of physical discomfort, consult with a physician.

Requirements of the Occupational Safety & Health Administration appear at www.osha.gov; the International Labor

Organization at http://www.ilo.org/safework/info/lang--en/WCMS_108566/index.htm; and the European Network for Silica at <http://www.nepsi.eu/good-practice-guide.aspx>.

In addition to any other applicable safety measures, the safety rules below must be followed to ensure employees safety:

Display a “Hazardous Dust” sign in all areas with hazardous dust.

Wear a suitable dust mask in all areas displaying a “Hazardous Dust” sign.

Use dust control systems. Check that the dust intake, filtration and expulsion systems are functioning correctly.

Use wet tools to prevent airborne dust particles.

Check that the work area is clean at the end of each shift.

Wear protective apparel when cleaning and maintaining machinery.

Wear designated work apparel at the worksite, including shoes and socks.

Change into work clothes at the worksite. Shower and change into clean clothes before leaving the worksite. Wash the clothes before reuse.

Do not clean work clothes, machines or floors with compressed air.

Perform cleaning only with a suitable vacuum cleaner.

Eating, drinking and smoking are permitted only in designated areas that are not exposed to hazardous dust.

Wash hands and face before eating, drinking and smoking.

Workers must undergo medical tests as required by local regulations.

Inspection

Prior to starting the fabrication, inspect the slab(s) by the following procedure:

Clean the slabs.

Check the slabs for any cracks, chips or voids, or any other defects, in a well-lighted area.

Check the colour of the slabs by visual inspection.

Check the warpage of the slab.

Check if material available is sufficient.

Check if all the tools required for fabrication are available.

Color Matching

QUARTZIA® slabs contain approximately 93% natural quartz. This may result in slight color variations between production cycles.

Each production cycle carries different batch numbers. The batch number appears on the label affixed to all slabs. The batch number is also stamped on the back of the slab.

Use slabs from the same batch for each job. This should ensure a color match. However, always perform a visual color match before cutting to confirm consistency in shading.

Measuring

It is always convenient to keep tape measure, spirit level, square, pencils, rulers, framing paper, templating material etc., handy.

The dimensions are calculated by measuring the furniture and adding the dimensions required for the specific edge or overhang.

The joints should be designed in such a way that they go unnoticed, are symmetrical and use the least amount of material as possible.

Measure the width and length of each piece two times to ensure accuracy.

We recommend leaving a space of 1/4" between the slab and the wall to allow for expansion.

Do not install slab over any existing backsplash.

Check the location of the cutouts for faucets, drain pipes etc..and leave a distance between the cutout and the back edge. Allow some extra space if a backsplash is included.

All cut outs are to be clearly marked viz., sink cut-outs, electrical, cooktop or slide in range, etc.

There is no harm in reverifying the levelness of the cabinets and the "squareness" of the walls.

Edges need to be clearly noted by type, location and finish.

Remember that all angles should be conveyed to the drawing.

Once your measurement is completed you should have all the relevant information on drawing including the following:

Back splashes locations and sizes

Countertop dimensions

Cutouts dimensions

Edge location and sizes

Faucet holes location(s) and sizes

Interior cabinet dimensions

Overhangs location and dimension

Material color

Sink location and model information

Stove location and model information

Seam Location

Windowsill dimension

General Guidelines

Do not change the factory finish of the slab. It is to be utterly avoided.

To avoid overheating the slab, only water-cooled tools should be used for cutting, drilling, and polishing.

To avoid the part from moving, place the anchoring elements near the cutting line.

First cut, along the longest part of the slab and then the shortest part. **QUARTZIA®** should be cut to size, shaped and polished with the appropriate diamond tooling using enough water to keep the surface cool and dust level low. High pressure water jets can also be used for cutting.

For thick or warped slabs, double cutting technique should be use, i.e., first cutting the material to half the thickness.

Every corner must be rounded with a minimum radius of 10mm; by doing this the breakage possibilities are greatly reduced. Rounding of corners is not necessary on L-shaped counters where seams fall at corners.

The cuts should never cross in the corners, as this can cause breakage of the work top in future.

When cutting an inside corner, always use a core bit to avoid damaging the corner area with the cutting disc. Damage to the radius area will create a stress point.

Ensure that all internal corners have a minimum 6mm radius to reduce corner stresses. Similarly all top and bottom edges of straight-edge profiles should have a minimum of 1.5 mm radius or should be chamfered.

Cutting Straight Lines

Machine cut straight lines with a flat diamond disk mounted on a table-mounted saw or bridge saw.

Cut straight lines manually with a flat diamond disk mounted on a suitable angle grinder.

Be sure to use the correct diameter diamond disk for the machine and the material.

Cutting Curved Lines

Machine cut curved lines by one of the following methods:

CNC with diamond finger bit

Water jet cutter

Cut curved lines manually by one of the following methods:

Router with diamond finger bit

Grinding wheel with concave diamond disk

Cutting Holes

Machine cut holes by one of the following methods:

Drilling machine with diamond cup drill

CNC with diamond cup drill

Water jet cutter

Cut holes manually with a carbide-tipped drill bit (for small holes) or a diamond cup drill mounted on a suitable angle grinder or manual drill (for larger holes).

Polishing Edges

Follow the guidelines below to achieve an edge polish equal to the factory surface polish.

Never polish the face of the surface, only the edge!

Ensure that the area to be polished is clean of debris.

Use water-cooled tools for polishing; dry polishing may overheat and damage the area.

Use suitable diamond polishing pads with water.

Use a polishing bob for polishing rounded or curved inside corners and small cutouts with exposed edges.

Perform polishing by progressing through the various grit sizes from coarse (lower number) to fine (higher number).

When a significant amount of material must be removed from the edge, a diamond grinding wheel can be used before the coarsest pad.

Each stage of polishing should remove the marks of the previous stage. When a uniform finish is achieved, progress to the next stage.

It is recommended not to use polishing stones for manual polishing.

Do not polish edge profiles in excess of the factory surface polish.

Polish edge profiles in a progressive manner according to the tables opposite.

Polished Finishes

Polished finishes are • smooth and shiny.

Create polished finishes by using **diamond polishing pads**.

Avoid over polishing, e.g., with a 3000 grit pad, as this will make the polished area more shiny and smooth than the surface.

Accessory Grit Size

Green diamond polishing pad 60

Black diamond polishing pad 80

Red diamond polishing pad 120

Yellow diamond polishing pad 400

White diamond polishing pad 800

Blue diamond polishing pad 1500

Always polish edges with enough water to keep the surface cool and limit dust formation. Pressure and rotation speed should be kept low. In case the edges are polished without water it may cause overheating thereby subjecting the edge to chipping or may result in a hairline crack in the slab. Excessive heat generated due to this would undermine the physical structure of the slab and may lead to physical and or mechanical damage to the slab.

The edge is to be polished in a sequence, starting with rough grinding then followed by using tools or pads with a finer grit until the desired surface finish is achieved. Do not over polish edges in excess of the factory polish.

For making holes, the cutting direction should be counter – clockwise.

Masking tape should be installed where scribing is required.

A line should be noted which reflects the cutting line.

Use diamond blades to cut the piece vertically.

Preparing the Base Units/Cabinets

Before installing the surface, ensure that cabinets are complete, stable, level and suitable for bearing the weight of the surface. The cabinets should be fixed to each other and then secured to the back wall.

Countertops

Preparation for Installation

Place all the fabricated pieces of the surface in their final position on the cabinets without adhesive. Check that all the pieces are the correct size, shape and direction in relation to the cabinets and the walls.

Check that all exposed edges and corners are fabricated and rounded as required.

Check that the surface is straight and level with a spirit level and long ruler.

Leave a space of 1 mm (1/32") per linear meter between straight stretches of the surface and each wall for expansion and contraction, but not less than 3 mm (1/8") in any event.

Before securing the surface to the cabinets, perform a final visual inspection to ensure that the surface is to your satisfaction.

Seaming

Part the fabricated pieces of surface slightly at the seam.

Place a layer of paper on the cabinet underneath the seam in order to prevent the adhesive from sticking the surface to the cabinet.

Prepare a suitable color-matched polyester resin adhesive. If necessary, mix the adhesive with pigments with a stainless steel or plastic spatula until achieving the required shade.

Use a plastic spatula for mixing light colors.

Ensure that the seam is clean of debris.

Spread a generous amount of the adhesive on both sides of the seam.

Ensure that the groove in the middle of the seam is filled with adhesive.

Close, secure and straighten the seam with clamps or a professional seaming clamp to create a smooth, flush surface.

Do not glue large surfaces to the cabinets. Only small surfaces that may move should be glued to the cabinets with dabs of flexible adhesive, e.g., 100% silicone.

After the adhesive is completely dry, remove the clamps.

Remove any excess adhesive with a scraper.

Perform final cleaning with alcohol on a clean white cloth.

Do not polish seams on **QUARTZIA®** surfaces.

QUARTZIA® surfaces must be supported on a strong perimeter frame or on a full deck support of plywood.

Verify that the countertop is sufficiently supported in areas of seams, cutouts and over spaces for appliances such as dishwashers, ovens, washing machines, etc.

Provide front-to-back support underneath the surface every 500-600 mm (20-24").

Examples of support are: wooden beams inside cabinets; console attached to the wall; upright countertop to floor panel.

For cutouts longer than 600 mm (24"), provide side-to-side support beams under the surface

Provide support under all countertop seams.

Attach a wooden board between the cabinet tops on both sides of undercounter appliances that generate heat.

For surfaces of 13 mm and 20 mm, if extra reinforcement of the cabinets or the surface is considered necessary, lay a plywood subtop at least 16 mm (5/8") thick on top of the cabinets, or glue strips of **QUARTZIA®** material under the surface. For surfaces of 30 mm (1 1/4") a full subtop is not required

Sealing Between the Surface and the Wall

Clean the space between the surface and the wall.

Fill the space generously with a flexible adhesive such as neutral 100% silicone.

The silicone adhesive prevents water from entering the cabinet.

For visible joins between the **QUARTZIA®** surface and a different material, use colored silicone or a suitable acrylic mastic.

If the cabinets are supported on adjustable legs, ensure that all legs are evenly tensioned to ensure stability.

Sinks

Install, glue and seal the sink as per the manufacturer's instructions after installing the surface.

Glue and seal the sink to the surface with a suitable flexible adhesive.

Ensure that the sink is fully supported inside the cabinet, e.g., by support rails or legs connected to the cabinet, in addition to being attached to the **QUARTZIA®** surface

Under mount Sinks

Kitchen sink faucet should be installed on the underside of the counter top.

Build-up should be installed around the perimeter of the sink using plywood or 5/8" MDF.

On the outside of the brackets support strips should be installed from front to back.

The sink and support strips should flush with each other.

The flange of sink should be cleaned with denatured alcohol before colour matched silicone sealant is applied.

The under mount sinks with pre-drilled holes must have at the back a minimum of 1 ½" clearance.

The under mount sinks without pre-drilled holes must have the back a minimum of 4 ½" clearance.

The dimension of hole should be verified, generally it is either 1 ¼ " or 1 ½".

QB 6801

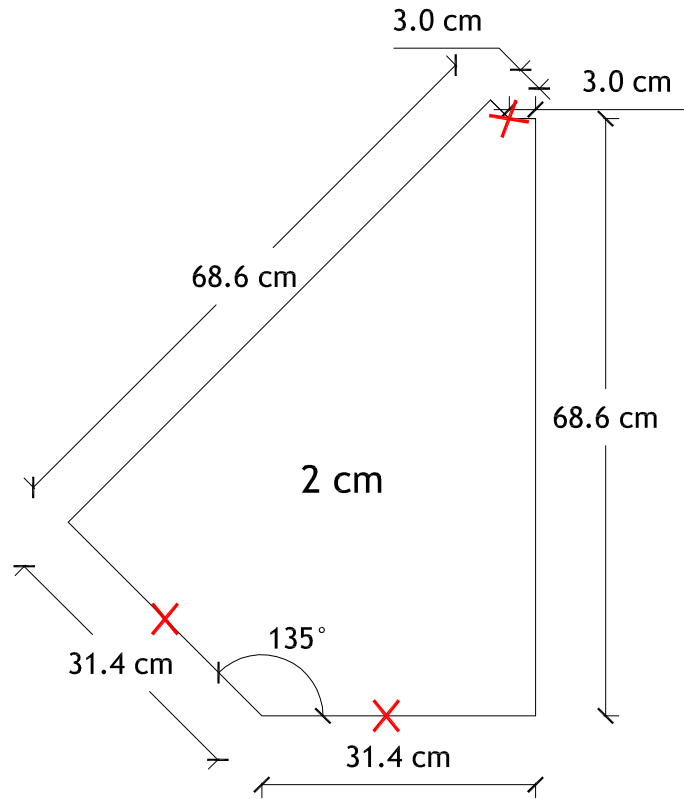

Centimeters

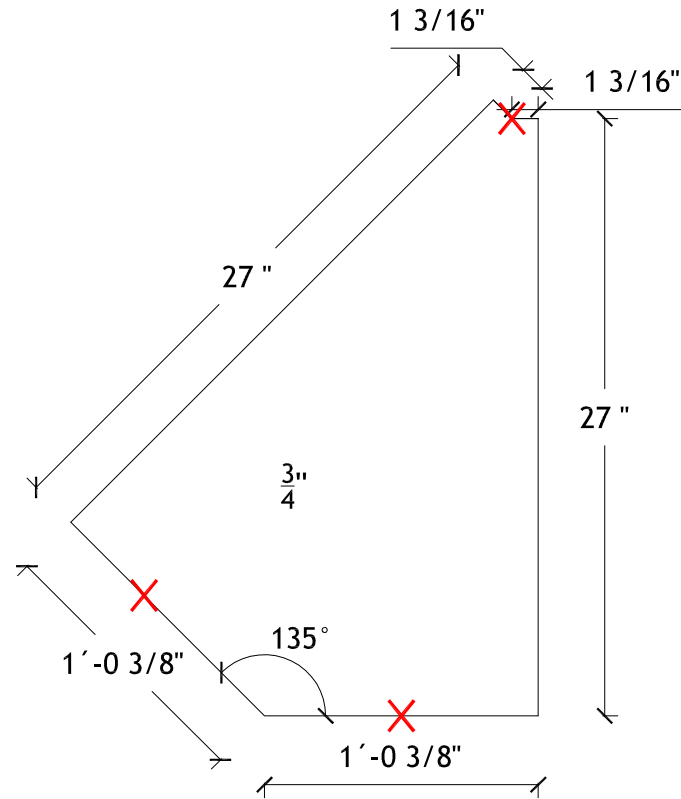

Inches

X =Eased+Polished Edge

LEVANTINA
THE NATURAL STONE COMPANY

PROYECTO/PROJECT:

CLIENTE/CUSTOMER:

DESCRIPCION/DESCRIPTION:
QB 6801

TECHNICAL
DEPARTMENT

FECHA/DATE:

20/12/11

REVISION / CHEK:

jchs

ESCALA/SCALE:

S/E

DRWG N°:

1

QB 6802

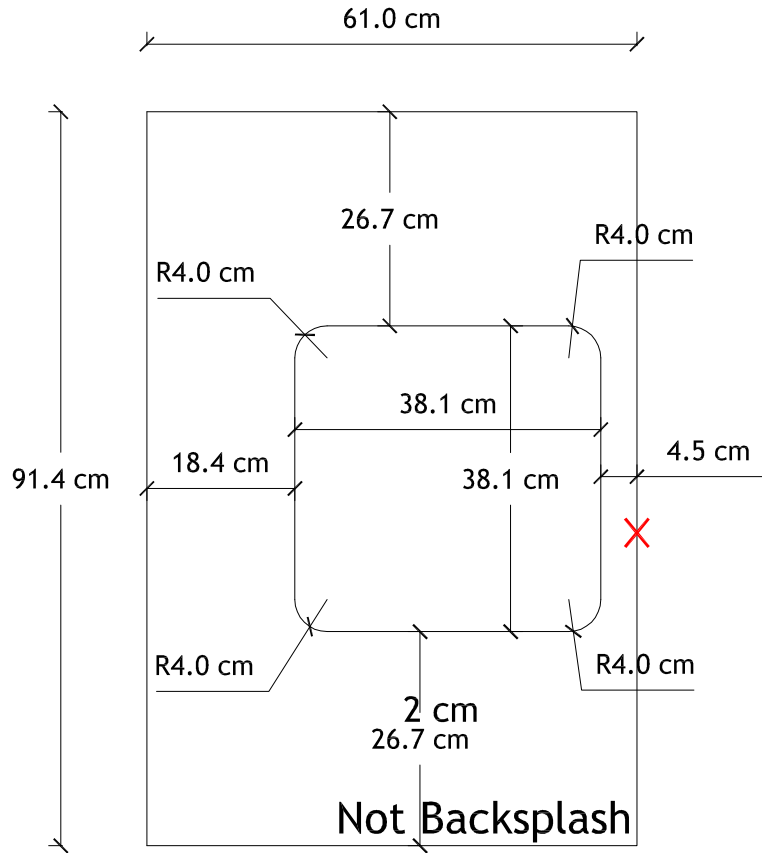

Centimeters

X =Eased+Polished Edge

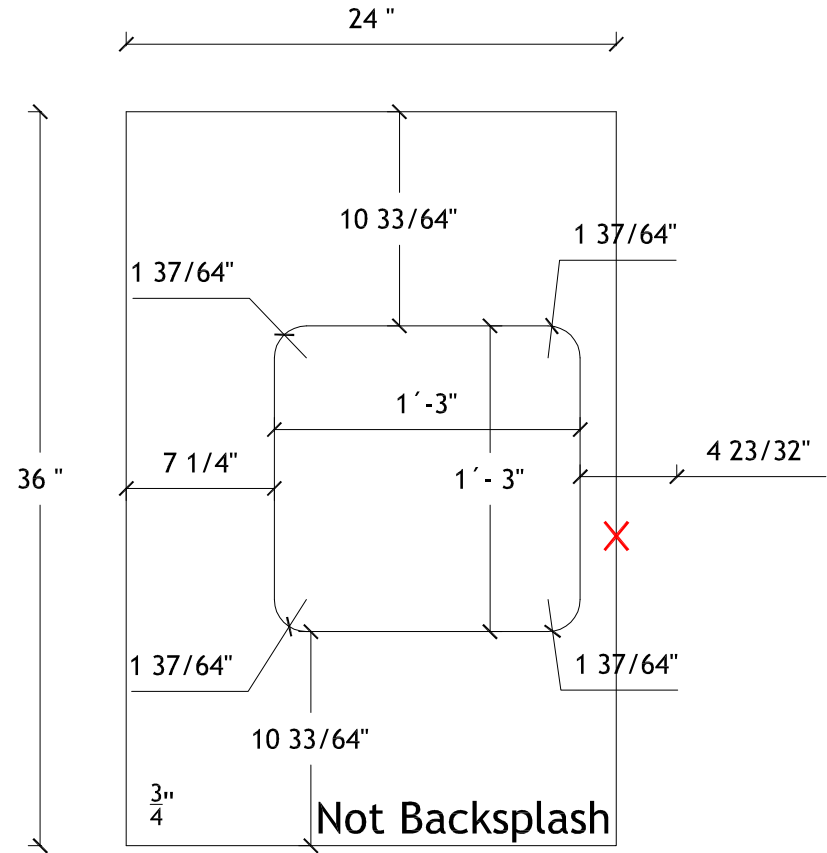

Inches

LEVANTINA
THE NATURAL STONE COMPANY

PROYECTO/PROJECT:

CLIENTE/CUSTOMER:

DESCRIPCION/DESCRIPTION:

QB 6802

TECHNICAL
DEPARTMENT

FECHA/DATE:

20/12/11

REVISION / CHEK:

jchs

ESCALA/SCALE:

S/E

DRWG N°:

2

QB 6804

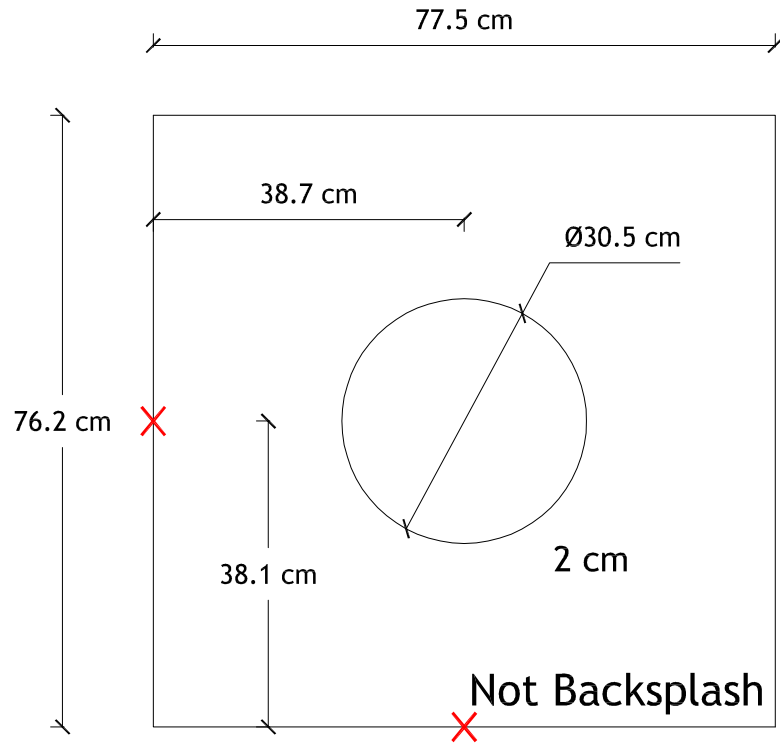

Centimeters

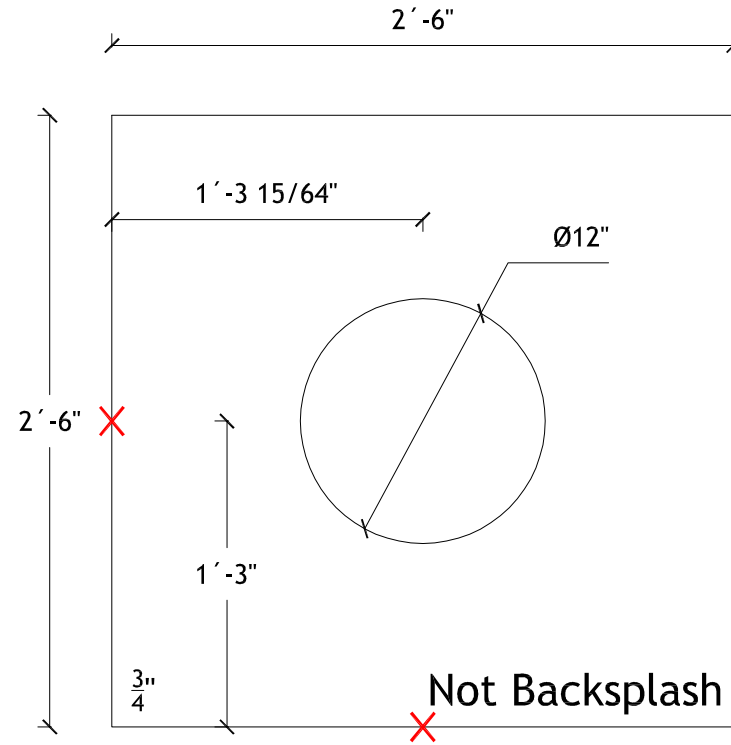

Inches

X = Eased + Polished Edge

LEVANTINA
THE NATURAL STONE COMPANY

PROYECTO/PROJECT:

CLIENTE/CUSTOMER:

DESCRIPCION/DESCRIPTION:
QB 6804

TECHNICAL
DEPARTMENT

FECHA/DATE:

20/12/11

REVISION / CHEK:
jchs

ESCALA/SCALE:

S/E

DRWG N°:

3

QB 6803

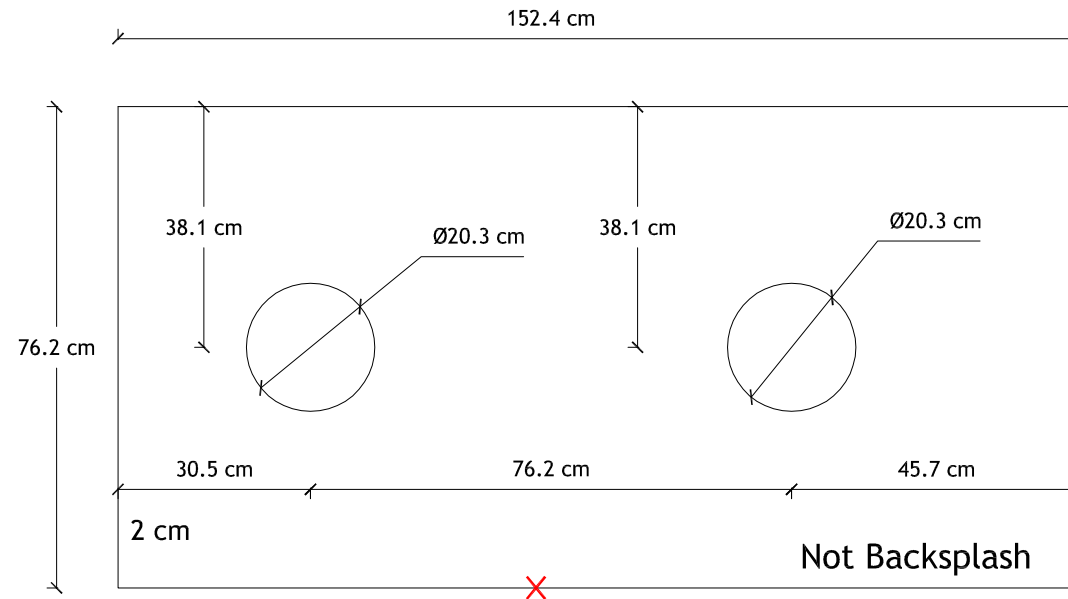

Centimeters

2

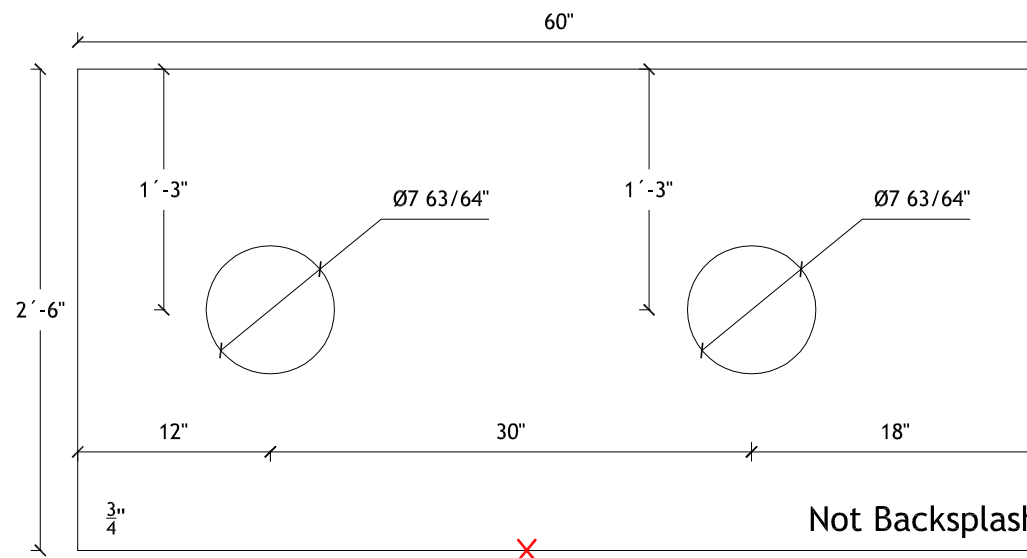

Inches

X = Eased + Polished Edge

LEVANTINA
THE NATURAL STONE COMPANY

PROYECTO/PROJECT:

CLIENTE/CUSTOMER:

DESCRIPCION/DESCRIPTION:
QB 6803

TECHNICAL
DEPARTMENT

FECHA/DATE:

20/12/11

REVISION / CHEK:
jchs

ESCALA/SCALE:

S/E

DRWG N°:

4

QB6805

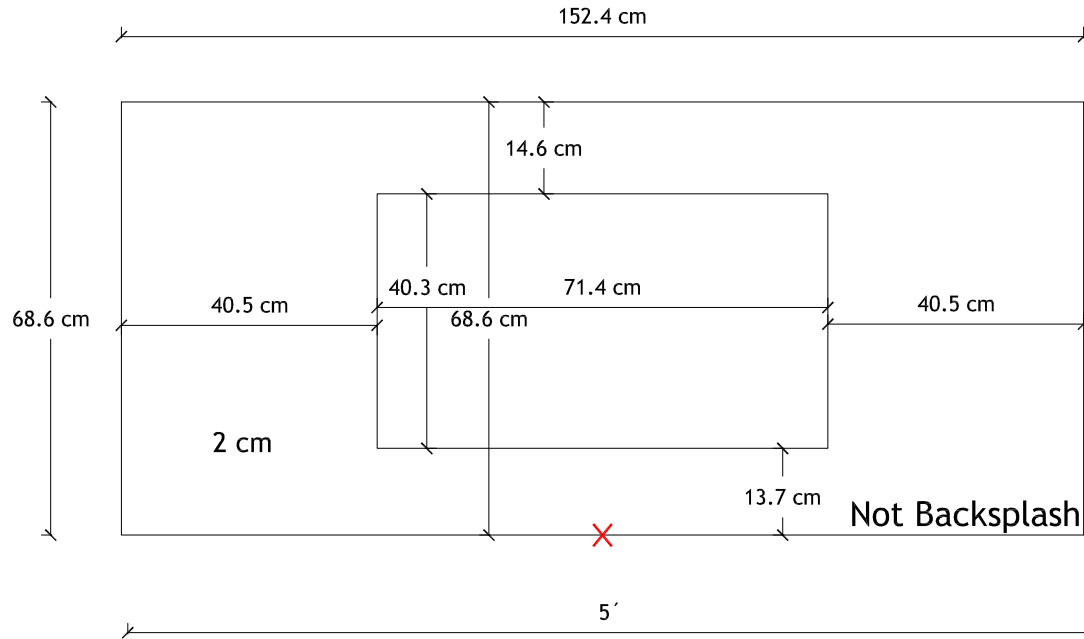

Centimeters

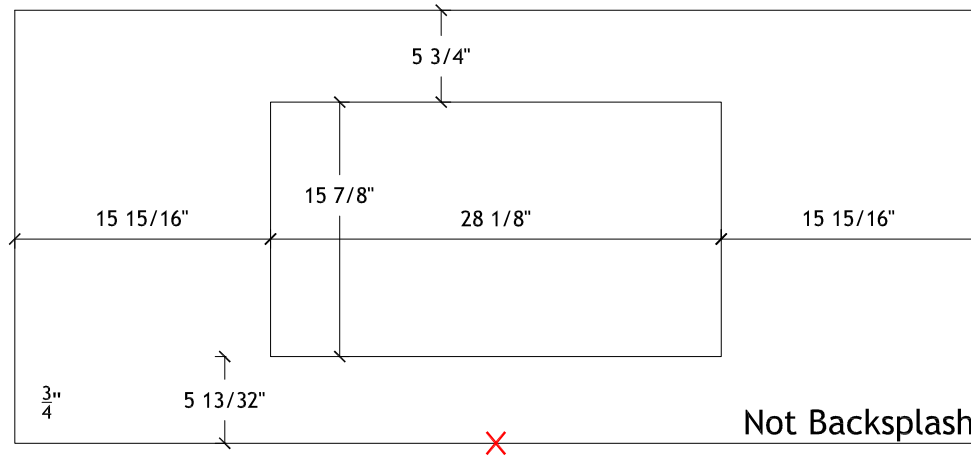

✗ =Eased+Polished Edge

Inches

LEVANTINA
THE NATURAL STONE COMPANY

PROYECTO/PROJECT:

CLIENTE/CUSTOMER:

DESCRIPCION/DESCRIPTION:
QB 6805

TECHNICAL
DEPARTMENT

FECHA/DATE:

20/12/11

REVISION /CHEK:
jchs

ESCALA/SCALE:

S/E

DRWG N°:

5

QB 6806. COUNTERTOP BLANK

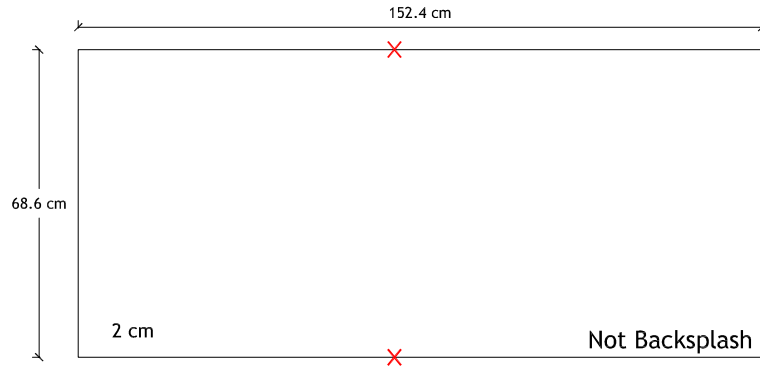

Centimeters

QB 6806. COUNTERTOP BLANK

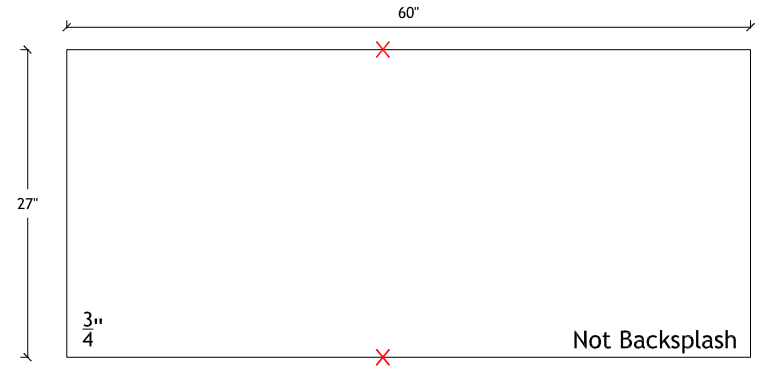

X =Eased+Polished Edge

Inches

QB 6807. BACKSPLASH

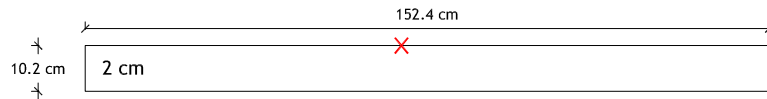

QB 6807. BACKSPLASH

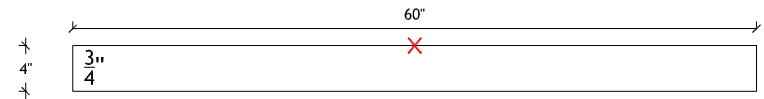

QB 6808. WALL CAP/PRIVACY WALL

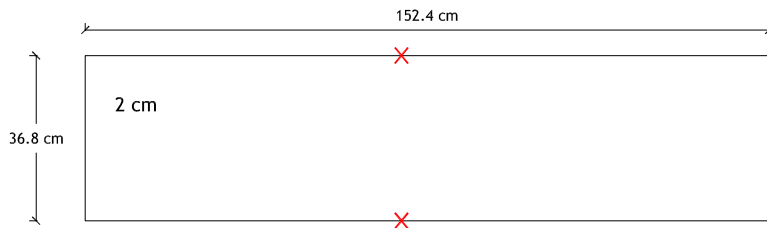

QB 6808. WALL CAP/PRIVACY WALL

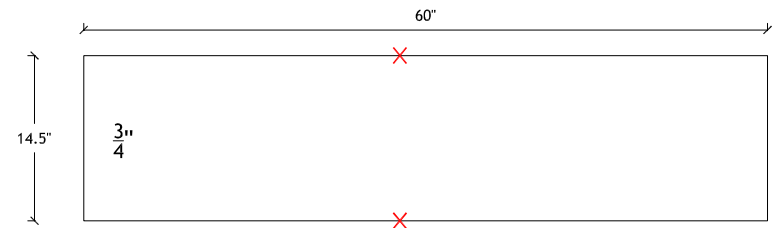

LEVANTINA
THE NATURAL STONE COMPANY

PROYECTO/PROJECT:

CLIENTE/CUSTOMER:

DESCRIPCION/DESCRIPTION:

QB6806, QB6807, QB6808

TECHNICAL
DEPARTMENT

FECHA/DATE:

20/12/11

REVISION /CHEK:
jchs

ESCALA/SCALE:

S/E

DRWG N°:

6

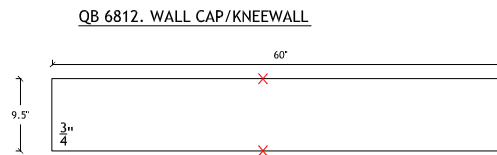
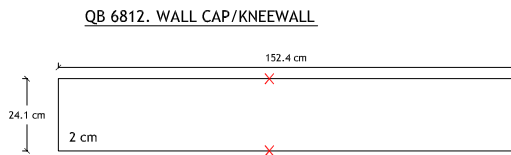
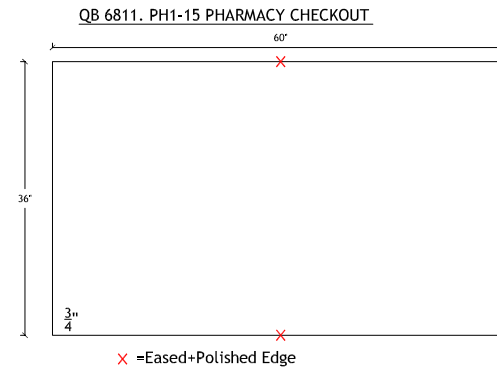
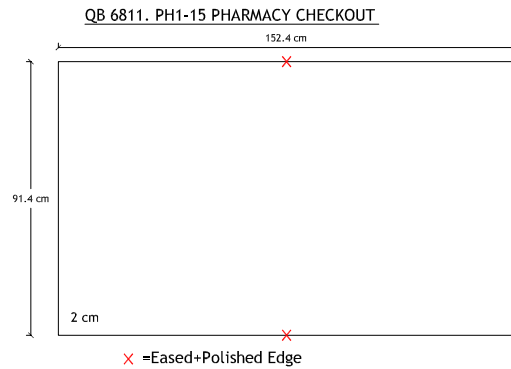
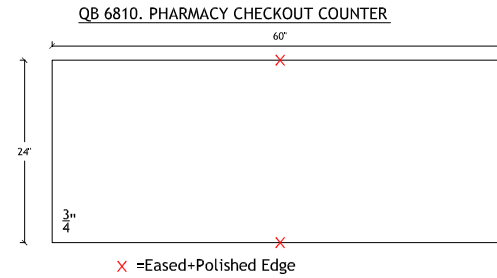
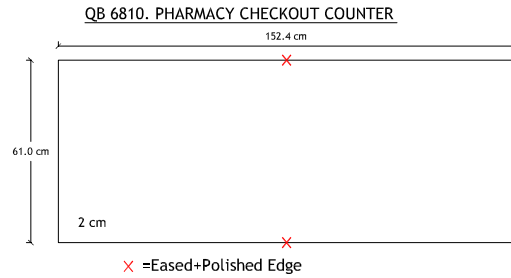
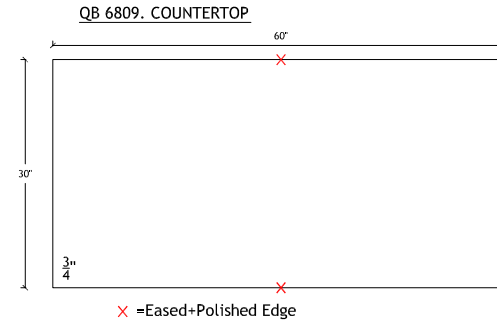
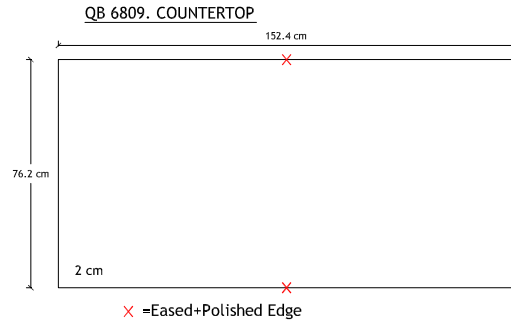

QB 6813. WALL CAP/KNEEWALL

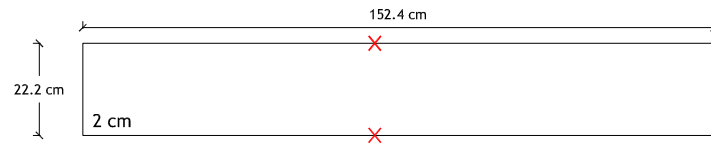

QB 6813. WALL CAP/KNEEWALL

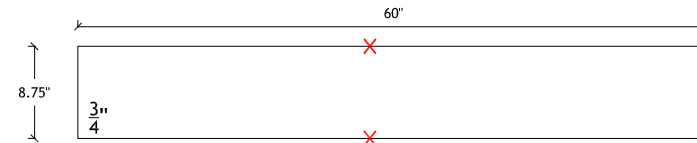

QB 6814. WALL CAP/KNEEWALL

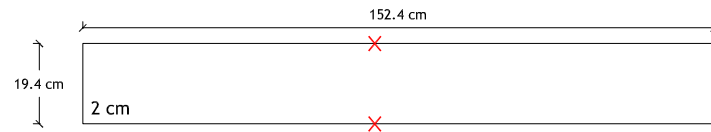

QB 6814. WALL CAP/KNEEWALL

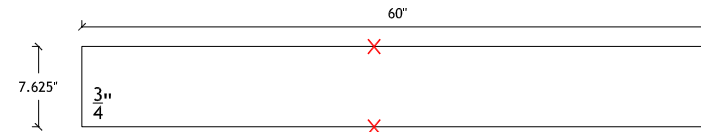

X =Eased+Polished Edge

X =Eased+Polished Edge

QB 6815. WALL CAP/KNEEWALL

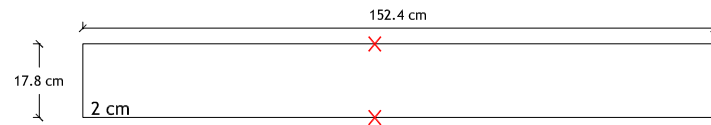

QB 6815. WALL CAP/KNEEWALL

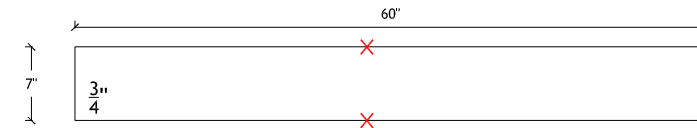

QB 6816. WALL CAP/KNEEWALL

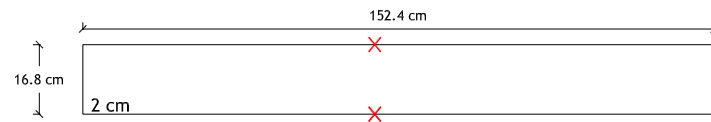

QB 6816. WALL CAP/KNEEWALL

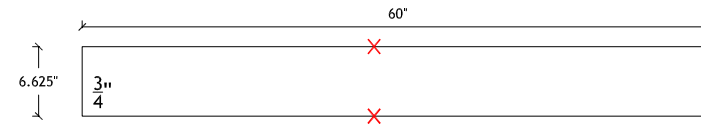

X =Eased+Polished Edge

X =Eased+Polished Edge

QB 6817. WALL CAP

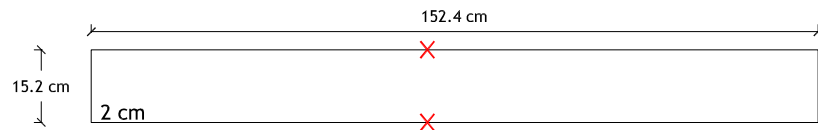

× =Eased+Polished Edge

QB 6817. WALL CAP

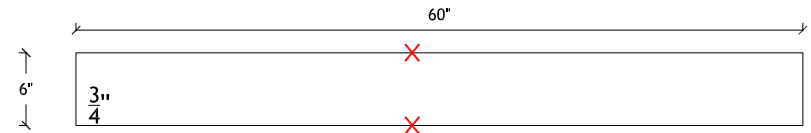

× =Eased+Polished Edge

QB 6818. COUNTERTOP

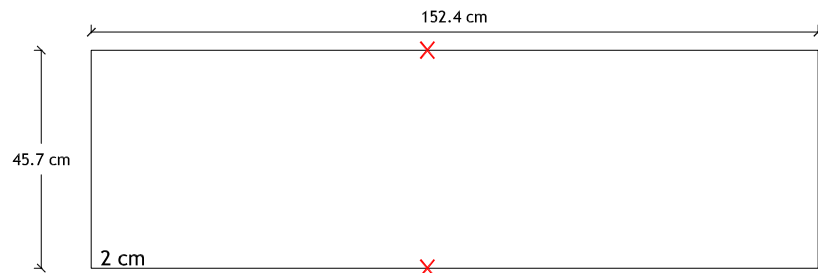

× =Eased+Polished Edge

QB 6818. COUNTERTOP

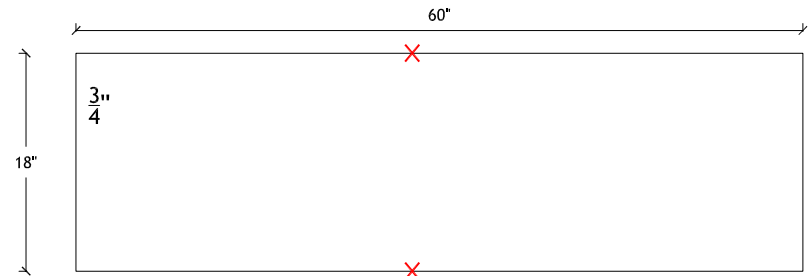

× =Eased+Polished Edge



NSF Product and Service Listings

These NSF Official Listings are current as of **Thursday, March 17, 2011** at 12:15 a.m. Eastern Time. Please [contact NSF International](#) to confirm the status of any Listing, report errors, or make suggestions.

Alert: NSF is concerned about fraudulent downloading and manipulation of website text. Always confirm this information by clicking on the below link for the most accurate information: <http://www.nsf.org/Certified/food/Listings.asp?TradeName=quantra&>

NSF/ANSI STANDARD 51 Food Equipment Materials

Pokarna Engineered Stone Limited

105, Surya Towers
Sardar Patel Road, Secundrabad
Andhra Pradesh 500003
India
91 40 27842182
[Visit this company's website](#)

Facility : Vishakapatnam, Andhra Pradesh, India

Trade Designation	Color	Type of Food	Maximum Temperature of Use in °F
Solid Surfacing for Splash Zone[1]			
Quantra™ 106	Montecristo	N/A	N/A
Quantra™ 128	Azul Fiorito	N/A	N/A
Quantra™ 132	Rock Salt	N/A	N/A
Quantra™ 141	Walnut Brownie	N/A	N/A
Quantra™ 181	Astoria	N/A	N/A
Quantra™ 208	Ginger	N/A	N/A
Quantra™ 225	Sand Dune	N/A	N/A
Quantra™ 252	Coffe Cloud	N/A	N/A
Quantra™ 254	Caramel Mocha	N/A	N/A
Quantra™ 266	Crème Caress	N/A	N/A
Quantra™ 267	Bracken	N/A	N/A
Quantra™ 271	Petro/Nero	N/A	N/A
Quantra™ 287	Copper Mountain	N/A	N/A
Quantra™ 289	Giallo Antico	N/A	N/A

Quantra™ 318	Terracotta	N/A	N/A
Quantra™ 342	Hot Chocolate	N/A	N/A
Quantra™ 348	Coral Sand	N/A	N/A
Quantra™ 354	Sahara Storm	N/A	N/A
Quantra™ 360	Pebble Exotica	N/A	N/A
Quantra™ 365	Winter Haze	N/A	N/A
Quantra™ 389	Mexican Summer	N/A	N/A
Quantra™ 392	Rouge	N/A	N/A
Quantra™ 457	Flores	N/A	N/A
Quantra™ 489	Mirage	N/A	N/A
Quantra™ 502	Cocoa Truffle	N/A	N/A
Quantra™ 506	Cantina	N/A	N/A
Quantra™ 525	Dew Drops	N/A	N/A
Quantra™ 542	Ecru	N/A	N/A
Quantra™ 545	Corfu	N/A	N/A
Quantra™ 546	Black Olive	N/A	N/A
Quantra™ 553	Golden Mist	N/A	N/A
Quantra™ 555	Autumn Sunset	N/A	N/A
Quantra™ 556	Polar	N/A	N/A
Quantra™ 557	Desert Rose	N/A	N/A
Quantra™ 561	Athens	N/A	N/A
Quantra™ 582	Paros	N/A	N/A
Quantra™ 612	Silver Oak	N/A	N/A
Quantra™ 633	Ios	N/A	N/A
Quantra™ 634	Mykanos	N/A	N/A
Quantra™ 635	Santorini	N/A	N/A
Quantra™ 657	Ipanema	N/A	N/A
Quantra™ 671	Fantasy Oro	N/A	N/A
Quantra™ 675	Tropical Forest	N/A	N/A
Quantra™ 680	River Bed	N/A	N/A
Quantra™ 684	Marvel	N/A	N/A
Quantra™ 685	St.Tropez	N/A	N/A
Quantra™ 695	Havana	N/A	N/A
Quantra™ 698	Carrara	N/A	N/A
Quantra™ 705	Ashley	N/A	N/A
Quantra™ 706	Sangria	N/A	N/A
Quantra™ 707	Jaipur	N/A	N/A
Quantra™ 718	Mistral	N/A	N/A
Quantra™ 729	Casablanca	N/A	N/A
Quantra™ 747	Elemento	N/A	N/A
Quantra™ 783	Sherry	N/A	N/A
Quantra™ 800	Sambuca	N/A	N/A
Quantra™ 802	Citrus	N/A	N/A
Quantra™ 807	Engles	N/A	N/A
Quantra™ 808	Fuji	N/A	N/A
Quantra™ 809	Vesuvius	N/A	N/A
Quantra™ 812	Marrakech	N/A	N/A
Quantra™ 854	Ciroc	N/A	N/A
Quantra™ 881	Pure	N/A	N/A
Quantra™ 886	Southend	N/A	N/A
Quantra™ 903	Moscow	N/A	N/A
Quantra™ 908	Velutina	N/A	N/A
Quantra™ 924	Era	N/A	N/A

Quantra™ 944	Coal Mine	N/A	N/A
Quantra™ 970	Kalbelia	N/A	N/A
Quantra™ 972	Pineapple Punch	N/A	N/A
Quantra™ 991	Aurora	N/A	N/A
Quantra™ 998	Charm	N/A	N/A
Quantra™ 1028	Asta	N/A	N/A
Quantra™ 1042	Honey Mustard	N/A	N/A
Quantra™ 1046	Bamboo Shoot	N/A	N/A
Quantra™ 1047	Olive Garden	N/A	N/A
Quantra™ 1064	Emotion	N/A	N/A
Quantra™ 1071	Salt & Pepper	N/A	N/A
Quantra™ 1076	Muduro Leaf	N/A	N/A
Quantra™ 1080	Schwarz	N/A	N/A
Quantra™ 1101	Spice Burst	N/A	N/A
Quantra™ 1107	Carbon	N/A	N/A
Quantra™ 1121	Inverra	N/A	N/A
Quantra™ 1128	Scabas	N/A	N/A
Quantra™ 1131	Opera	N/A	N/A
Quantra™ 1162	Sage	N/A	N/A
Quantra™ 1180	Snow Ash	N/A	N/A
Quantra™ 1194	Cardamom	N/A	N/A
Quantra™ 1219	Moon Dust	N/A	N/A
Quantra™ 1224	Sea Weed	N/A	N/A
Quantra™ 1229	Suede	N/A	N/A
Quantra™ 1256	California	N/A	N/A
Quantra™ 1267	Brushed Pearls	N/A	N/A
Quantra™ 1268	Grigio	N/A	N/A
Quantra™ 1293	Butter Cookie	N/A	N/A
Quantra™ 1301	Haystack	N/A	N/A
Quantra™ 1314	Paramo	N/A	N/A
Quantra™ 1334	Carnation	N/A	N/A
Quantra™ 1340	Veracruz	N/A	N/A
Quantra™ 1369	Cape Town	N/A	N/A
Quantra™ 1370	Fossil	N/A	N/A
Quantra™ 1398	Tornado	N/A	N/A
Quantra™ 1407	Cybele	N/A	N/A
Quantra™ 1410	Contrail	N/A	N/A
Quantra™ 1417	Mammatus	N/A	N/A
Quantra™ 1425	Noctilucent	N/A	N/A
Quantra™ 1455	Cirrus	N/A	N/A
Quantra™ 1517	Macadamia	N/A	N/A
Quantra™ 1525	Lunar Night	N/A	N/A
Quantra™ 1547	Hazelnut	N/A	N/A
Quantra™ 1560	Portofino	N/A	N/A
Quantra™ 1568	Walnut	N/A	N/A
Quantra™ 1576	Chardonnay	N/A	N/A
Quantra™ 1578	Cabernet	N/A	N/A
Quantra™ 1580	Wenge	N/A	N/A
Quantra™ 1629	Nimbus	N/A	N/A

[1] Available in the following finishes: Polish, Matt/Honed, Easy Care, Egg, Velvet, Sandblasted, Ardesia, and UV.

Number of matching Manufacturers is 1
Number of matching Products is 116
Processing time was 1 seconds

- [Search Listings](#) |
- [News Room](#) |
- [About NSF](#) |
- [Careers](#) |
- [NSF Mark](#) |
- [Client Log-In](#)

- [Privacy Policy](#) |
- [Site Map](#) |
- [Request Info](#) |
- [Contact Us](#) |
- [Copyright © 2004 NSF International.](#)

The Intertek logo consists of the word "Intertek" in a white, sans-serif font, centered within a dark blue rounded rectangular background.

REPORT NUMBER: 100427783SAT-001A
ORIGINAL ISSUE DATE: July 27, 2011
REVISED DATE:

EVALUATION CENTER
Intertek Testing Services NA Inc.
16015 Shady Falls Road
Elmendorf, TX 78112

RENDERED TO

Levantina USA, Inc.
11180 Zodiac Lane
Dallas, TX 75229

Report of Testing "Quartzia Product Line" for compliance with the applicable requirements of the following criteria: ASTM E84-10b TEST FOR SURFACE BURNING CHARACTERISTICS OF BUILDING MATERIALS (UL 723, UBC 8-1, NFPA 255)

TEST REPORT

ABSTRACT

Specimen I. D.	"Quartzia Product Line"	
Test Standard:	ASTM E84-10b TEST FOR SURFACE BURNING CHARACTERISTICS OF BUILDING MATERIALS (UL 723, UBC 8-1, NFPA 255)	
Test Date:	July 27, 2011	
Client:	Levantina USA, Inc.	
Test Results:		
	FLAME SPREAD INDEX	5
	SMOKE DEVELOPED INDEX	90

This report is for the exclusive use of Intertek's Client and is provided pursuant to the agreement between Intertek and its Client. Intertek's responsibility and liability are limited to the terms and conditions of the agreement. Intertek assumes no liability to any party, other than to the Client in accordance with the agreement, for any loss, expense or damage occasioned by the use of the report. Only the Client is authorized to copy or distribute this report and then only in its entirety. Any use of Intertek name or one of its marks for the sale or advertisement of the tested material, product or service must first be approved in writing by Intertek. The observations and test results in this report are relevant only to the sample tested. This report by itself does not imply that the material, product, or service is or has ever been under an Intertek certification program.

Darrell Gonzales

Darrell Gonzales
Technician 2

July 27, 2011

Reviewed and approved:

Servando Romo

Servando Romo
Project Manager

July 28, 2011

Intertek

I. INTRODUCTION

This report describes the results of the ASTM E84-10b TEST FOR SURFACE BURNING CHARACTERISTICS OF BUILDING MATERIALS a method for determining the comparative surface burning behavior of building materials. This test is applicable to exposed surfaces, such as ceilings or walls, provided that the material or assembly of materials, by its own structural quality or the manner in which it is tested and intended for use, is capable of supporting itself in position or being supported during the test period.

The purpose of the method is to determine the relative burning behavior of the material by observing the flame spread along the specimen. Flame spread and smoke density developed are reported, however, there is not necessarily a relationship between these two measurements.

"The use of supporting materials on the underside of the test specimen may lower the flame spread index from that which might be obtained if the specimen could be tested without such support... This method may not be appropriate for obtaining comparative surface burning behavior of some cellular plastic materials... Testing of materials that melt, drip, or delaminate to such a degree that the continuity of the flame front is destroyed, results in low flame spread indices that do not relate directly to indices obtained by testing materials that remain in place."

This test method is also published under the following designations:

NFPA 255
UL 723
UBC 8-1

This standard should be used to measure and describe the properties of materials, products, or assemblies in response to heat and flame under controlled laboratory conditions and should not be used to describe or appraise the fire hazard or fire risk of materials, products, or assemblies under actual fire conditions. However, results of this test may be used as elements of a fire risk assessment which takes into account all of the factors which are pertinent to an assessment of the fire hazard of a particular end use.

II. PURPOSE

The ASTM E84 (25 foot tunnel) test method is intended to compare the surface flame spread and smoke developed measurements to those obtained from tests of mineral fiber cement board and select grade red oak flooring. The test specimen surface (18 inches wide and 24 feet long) is exposed to a flaming fire exposure during the 10 minute test duration, while flame spread over its surface and density of the resulting smoke are measured and recorded. Test results are presented as the computed comparisons to the standard calibration materials.

The furnace is considered under calibration when a 10 minute test of red oak decking will pass flame out the end of the tunnel in five minutes, 30 seconds, plus or minus 15 seconds. Mineral fiber cement board forms the zero point for both flame spread and smoke developed indexes, while the red oak flooring smoke developed index is set as 100.

III. TEST PROCEDURE

The tests were conducted in accordance with the procedures outlined in the ASTM E84. The specimens are placed directly on the tunnel ledges. As required by the standard, one or more layers of 0.25 inch thick reinforced concrete board are placed on top of the test sample between the sample and the tunnel lid. After the test, the samples are removed from the tunnel, examined and disposed of.

IV. REVISION SUMMARY

DATE	SUMMARY
July 27, 2011	Original

V. DESCRIPTION OF TEST SPECIMENS

Date Received:	7/18/11
Date placed in the conditioning room:	7/18/11
Conditioning (73°F & 50% R.H.):	9 days
Specimen Width (in):	24
Specimen Length (ft):	24
Specimen Thickness (in):	1.12
Total Specimen Weight (lbs):	720

Mounting Method:

The specimen was self-supporting. The polished side was exposed to the flames.

Specimen Description:

The specimen was described by the client as "Agglomerated stone that is made up of stone dust and particles mixed together with epoxy and resins".

The 24-ft. long test specimen consisted of twenty-four 1-ft. long x 24-in. wide x 1.12-in. thick cement tile pieces that were butted to one another from 0 to 24-ft.

The product was received by our personnel in good condition.

VI. TEST RESULTS & OBSERVATIONS

The test results, computed on the basis of observed flame front advance and electronic smoke density measurements are presented in the following table.

Test Specimen	Flame Spread Index	Smoke Developed Index
"Quartzia Product Line"	5	90

The data sheets are included in Appendix A. These sheets are actual print-outs of the computerized data system which monitors the tunnel furnace, and contain all calibration and specimen data needed to calculate the test results.

VII. OBSERVATIONS

During the test, the specimen was observed to behave in the following manner.

Time (min:sec)	Observations
5:56	A steady ignition is observed.
7:07	Flaking is observed
8:09	Cracking is observed.

After the burners were turned off, a 60+ second after flame was observed.

After the test, the specimen was observed to be damaged as follows:

Distance (FEET)	Damage Descriptions
0 - 4	The specimen was heavily charred.
4 - 8	The specimen was heavily discolored.
8 - 24	The specimen was discolored.

APPENDIX A
ASTM E84
DATA SHEETS

TEST RESULTS

FLAMESPREAD INDEX: 5

SMOKE DEVELOPED INDEX: 90

SPECIMEN DATA . . .

Time to Ignition (sec): 358
Time to Max FS (sec): 583
Maximum FS (feet): 2.9
Time to 980 F (sec): Never Reached
Time to End of Tunnel (sec): Never Reached
Max Temperature (F): 511
Time to Max Temperature (sec): 474
Total Fuel Burned (cubic feet): 50.14

FS*Time Area (ft*min): 5.8
Smoke Area (%A*min): 93.6
Unrounded FSI: 3.0

CALIBRATION DATA . . .

Time to Ignition of Last Red Oak (Sec): 39.0
Red Oak Smoke Area (%A*min): 104.9

FLAME SPREAD (ft)

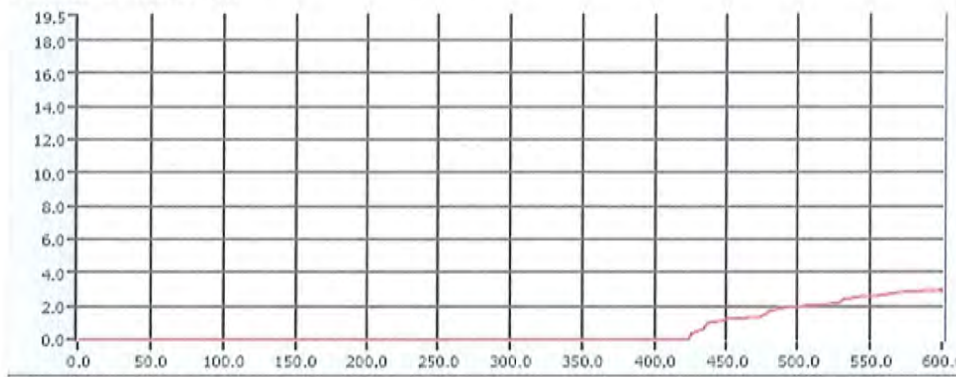

Smoke (%A)

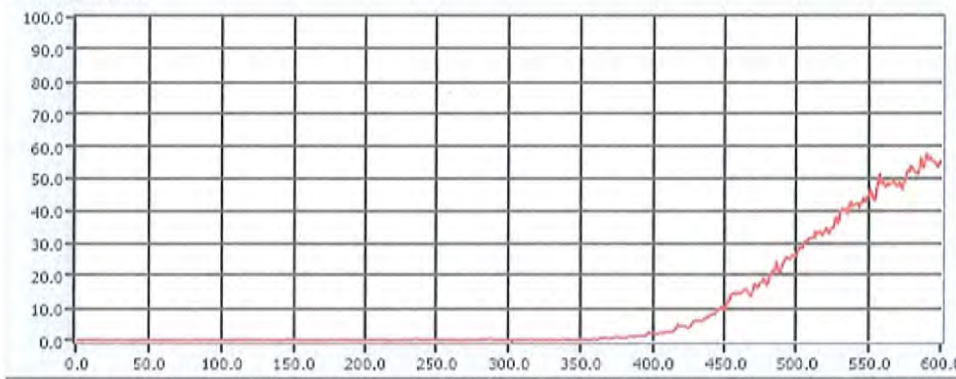

Temperature (F)

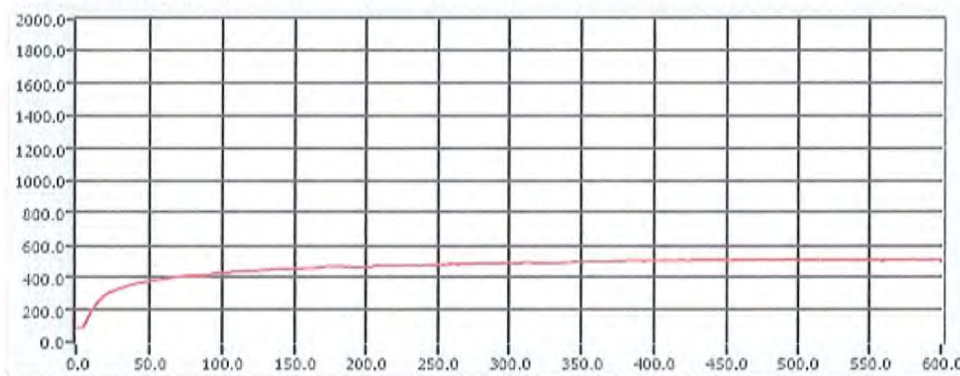

Time (sec)

600





SOLID SURFACE GLUE TECHNICAL DATA SHEET

DESCRIPTION

Seam-it™ by Glue Warehouse is a two-part Methacrylate adhesive designed for joining and seaming solid surfaces. Seam-it™ glue is formulated with the latest innovation in color matched adhesives for the surfacing industry: the Glue Warehouse Match Factor™. Seam-it™ is available in the most popular pre-mixed colors and offers excellent bonding to a variety of solid surface substrates including Acrylics, Polyesters, and Polyester blended Solid Surface materials. Seam-it™ has high resistance to water, impact and high temperatures and also possesses greater toughness and greater impact resistance than most other adhesives in the market.

Fabricators will benefit from the environmental conformance properties of Seam-it™ adhesives as well. It is manufactured to the highest standard available and faces stringent quality control tests prior to sale and distribution. In addition, Seam-It meets the requirements for Low VOC emission limits, established by the California SCAQMD – one of the most stringent regulations in the U.S.

Use of Seam-It Low VOC products can also qualify contractors for one credit toward the U.S. Green Building Council’s LEED certification for green building.

PERFORMANCE HIGHLIGHTS	
UV Stable Room Temperature Cure Minimum surface preparation	Excellent Water Resistance Excellent Scuffing Resistance Excellent Impact Resistance

TYPICAL ADHESIVE CHARACTERISTICS @ 75°F (24°C)			
	Part A Adhesive	Part B Activator	Mixed A + B
Color:	Multiple	Clear	Multiple
Mix ratio by volume:	10	1	--
Mix ratio by weight:	8.94	1	--
Viscosity, cps:	25,000 ± 5,000	5,000 ± 500	--
Density, g/ml	1.05	1.18	1.06
Unit weight, lb/gal	8.75	9.79	8.84
Working time, min:	10	--	--
Fixture time, min	20-25	--	--

TYPICAL PHYSICAL PROPERTIES @ 75°F (24°C)		RECOMMENDED SUBSTRATES
Tensile Strength, psi (ASTM D638)	5,000 – 7,000	Acrylic sheet
Flexural Strength, psi (ASTM D790)	4,000 – 5,000	Glass Reinforced Plastics
Butt Joint Tensile, psi	2,000 – 2,500	Polyester sheet
Hardness-Barcol, hardness (ASTM D2583)	50 – 60	Gel Coats



SOLID SURFACE GLUE TECHNICAL DATA SHEET

Color Range

- Seam-it colors are the most advanced colors available on the market .
- Extra care has been taken during the color match process to ensure that only the minimum number of colors is used to cover the widest range of available sheet colors.
- Glue Warehouse's exclusive Match Factor™ is the first process to quantify the quality of a given color match thereby reducing the overall number of colors needed.

Temperature Variance

- Shelf life and cure speed are both properties affected by temperature variables.
- Shelf life is shortened if the glue is stored at temperatures exceeding 80 F
- Shelf life of 2 years or more can be attained if stored at constant temperatures at or below 72 F.
- Glue will cure faster in a warm environment than a cold one.
- The optimum temperature range for dispensing Seam-it is between 60F and 90F

Dispensing

- Seam-it is available in the industry standard 250ml 10-1 cartridges.
- Recommended mixing tips are the MFX 8/18 or MFXQ 7/24

Storage

- Store Cartridges in a cool, dark, dry place between 50°F and 80°F. Keep away from heat, sparks, open flames and other combustible materials.
- Shelf life of 24 months when stored at constant temperatures at or below 72 F
- Always store the cartridges in an upright position

Handling

- Avoid contact with eyes, skin and clothing. Avoid breathing vapor and use only in areas with adequate ventilation. Wash hands thoroughly after use. KEEP AWAY FROM CHILDREN.
- Always wear safety glasses and gloves when using Seam-it glue.
- **Eyes** – Flush with water for 15 minutes and get immediate medical attention.
- **Skin** – Remove adhesive, wash with soap and water.
- **Inhalation** – If inhaled, move into fresh air.
- **Ingestion** – If swallowed, give 1 or 2 glasses of water. Do not induce vomiting. Contact physician immediately.

L E V A N T I N A

THE NATURAL STONE COMPANY

LEVANTINA	SEAM-IT COLOR
BURNT SIENNA	HERSHEY BROWN
KHINGAN CINNAMON	BROOKLYN BROWN
MCKINLEY GREY	BEDROCK GRAY
SIERRA BEIGE	BAILEYS CREAM
TUSCANY CANYON	CAMEL BROWN
WHITNEY RIDGE	SADDLE BROWN

Next day delivery nationwide.



GHS SAFETY DATA SHEET

Seam-it 2-Component Solid Surface Joint Adhesive (10:1 Mix Ratio)

Date Revised: **AUG 2010**

Supersedes:

SECTION I - PRODUCT AND COMPANY IDENTIFICATION

PRODUCT NAME: Seam-it 2-Component Solid Surface Joint Adhesive (10:1 Mix Ratio)

PRODUCT USE: Two component adhesive for bonding acrylic thermoplastic sheet and other composites.

SUPPLIER:

MANUFACTURER: IPS Corporation

600 Ellis Road, Durham, NC 27703 - USA

P.O. Box 12729, Research Triangle Park, NC 27709 - USA

Tel. 1-919-598-2400

EMERGENCY: Transportation: Tel. 800.424.9300, 703.527.3887 CHEMTREC (International)

Medical: Tel. 800.451.8346, 760.602.8703 3E Company (International)

SECTION 2 - HAZARDS IDENTIFICATION

GHS CLASSIFICATION:

Health		Environmental		Physical	
Acute Toxicity:	Category 4	Acute Toxicity:	Category III	Flammable Liquid:	Category 2
Skin Irritation:	Category 3	Chronic Toxicity:	Category IV		
Skin Sensitization:	YES				
Eye:	Category 2B				

GHS LABEL:



OR



WHMIS CLASSIFICATION: CLASS B, DIVISION 2
CONTROLLED PRODUCT CLASS D, DIVISION 2B

Hazard Statements

Highly flammable liquid and vapor May cause irritation/allergic skin reaction

Precautionary Statements

Do not breathe vapor Keep container closed Use in well-ventilated area

SECTION 3 - COMPOSITION/INFORMATION ON INGREDIENTS

Component	CAS#	EINECS #	REACH Pre-registration Number	CONCENTRATION % by Weight
Component "A" Methyl Methacrylate Monomer (MMA),* Stabilized	80-62-6	201-297-1	05-2116297731-37-0000	35 - 60
Component "B" Benzoyl Peroxide (BPO)*	94-36-0	202-327-6	05-2116297715-31-0000	<5%

All of the constituents of this adhesive product are listed on the TSCA inventory of chemical substances maintained by the US EPA, or are exempt from that listing.

*Indicates this chemical is subject to the reporting requirements of Section 313 of the Emergency Planning and Community Right-to-Know Act of 1986 (40CFR372).

SECTION 4 - FIRST AID MEASURES

- Contact with eyes:** Flush eyes immediately with plenty of water for 15 minutes and seek medical advice immediately.
- Skin contact:** Remove contaminated clothing and shoes. Wash skin thoroughly with soap and water. If irritation develops, seek medical advice.
- Inhalation:** Remove to fresh air. If breathing is stopped, give artificial respiration. If breathing is difficult, give oxygen. Seek medical advice.
- Ingestion:** Rinse mouth with water. Give 1 or 2 glasses of water or milk to dilute. Do not induce vomiting. Seek medical advice immediately.

SECTION 5 - FIREFIGHTING MEASURES

- Suitable Extinguishing Media:** Dry chemical powder, carbon dioxide gas, foam, Halon, water fog.
 - Unsuitable Extinguishing Media:** Water spray or stream.
 - Exposure Hazards:** Inhalation and dermal contact
 - Combustion Products:** Oxides of carbon, oxides of nitrogen, hydrogen chloride hydrocarbons, acrid smoke and gases.
 - Protection for Firefighters:** Self-contained breathing apparatus or full-face positive pressure air-supply masks.
- | | HMIS | NFPA | |
|--------------|------|------|------------|
| Health | 2 | 2 | 0-Minimal |
| Flammability | 3 | 3 | 1-Slight |
| Reactivity | 2 | 2 | 2-Moderate |
| | | | 3-Serious |
| | | | 4-Severe |

SECTION 6 - ACCIDENTAL RELEASE MEASURES

- Personal precautions:** Keep away from heat, sparks and open flame. Provide sufficient ventilation, use explosion-proof exhaust ventilation equipment or wear suitable respiratory protective equipment. Prevent contact with skin or eyes (see section 8).
- Environmental Precautions:** Prevent product or liquids contaminated with product from entering sewers, drains, soil or open water course.
- Methods for Cleaning up:** Contain spill with sand or other inert adsorbent or absorbent material. Use non-sparking tools. Transfer to a closable vessel (Metal or polyethylene [PE])

SECTION 7 - HANDLING AND STORAGE

- Handling:** Avoid breathing of vapor, avoid contact with eyes, skin and clothing. Keep away from ignition sources, use only electrically grounded handling equipment and ensure adequate ventilation/fume exhaust hoods. Do not eat, drink or smoke while handling.
- Storage:** Store in ventilated room or shade and away from direct sunlight. Keep container tightly closed when not in use. Keep away from ignition sources and incompatible materials. Follow all precautionary information on container label and product bulletins.

SECTION 8 - PRECAUTIONS TO CONTROL EXPOSURE / PERSONAL PROTECTION

EXPOSURE LIMITS:	Component	ACGIH TLV	ACGIH STEL	OSHA PEL	OSHA STEL
	Methyl Methacrylate Mon.	50 ppm	100 ppm	100 ppm	N/E
	Benzoyl Peroxide	5 mg/m ³	N/E	5 mg/m ³	N/E

- Engineering Controls:** Use local exhaust as needed.
- Monitoring:** Maintain breathing zone airborne concentrations below exposure limits.
- Personal Protective Equipment (PPE):**
- Eye Protection:** Avoid contact with eyes, wear splashproof chemical goggles, face shield, safety glasses (spectacles) with brow guards and side shields.
- Skin Protection:** Prevent contact with the skin as much as possible. Butyl rubber gloves should be used for frequent immersion. Use of solvent-resistant gloves or solvent-resistant barrier cream should provide adequate protection when normal adhesive application practices and procedures are used for making structural bonds.
- Respiratory Protection:** Use in a well-ventilated room. Use local exhaust ventilation to remove airborne contaminants from employee breathing zone and to keep contaminants below levels listed above. With normal use, the Exposure Limit Value will not usually be reached. When limits approached, use respiratory protection equipment.

SECTION 9 - PHYSICAL AND CHEMICAL PROPERTIES

Appearance:	"A" - Off-white, viscous liquid, "B" - Gray or Black viscous liquid	Odor Threshold:	"A" - 0.75 ppm: MMA
Odor:	"A" - Strong Solvent Odor, "B" - Mild Odor	Active Oxygen Content:	"B" - <1 %
pH:	Not Applicable	Evaporation Rate:	"A" - > 1.0, "B" - <1 (BUAC = 1)
Boiling Point:	"A" -100.5°C (212.9°F) Based on first boiling component: MMA "B" - Not Established	Flammability:	"A" - Category 2, "B" - Category 4
Flash Point:	"A" - 11.5°C (52.7°F) T.C.C. based on MMA, "B" - 84°C (184°F) for BPO	Flammability Limits:	LEL: "A" - 1.6% based on MMA UEL: "A" - 12.5% based on MMA
Specific Gravity:	"A" - 1.048, "B" - 1.175 @23°C (73°F)	Vapor Pressure:	LEL & UEL: "B" - Not Established "A" - 28 mm Hg @ 20°C (68°F): MMA "B" - N/E
Solubility:	"A" - Slight in Water (MMA, MAA), "B" - Insoluble in Water	Vapor Density:	"A" - > 3.0 (Air = 1), "B" - N/E
Auto-ignition Temperature:	"A" - 421 °C (789.8°F): MMA, "B" - Not Established	VOC Content :	"A" - ≤ 50 g/l mixed, "B" - None
Decomposition Temperature:	"A" - Not Applicable, "B" - 110°C (230 °F)		

SECTION 10 - STABILITY AND REACTIVITY

Stability:	Stable, unless heated
Hazardous decomposition products:	None in normal use. Oxides of carbon, oxides of nitrogen, hydrogen chloride, hydrocarbons, acrid smoke and gases.
Conditions to avoid:	Keep away from direct sunlight, heat, sparks, open flame and other ignition sources.
Incompatible Materials:	Reducing and oxidizing agents and metal contaminants

SECTION 11 - TOXICOLOGICAL INFORMATION

Likely Routes of Exposure: Inhalation, Eye and Skin Contact

Acute symptoms and effects:

Inhalation:	Severe overexposure may result in nausea, dizziness, headache. Can cause drowsiness, irritation of eyes and nasal passages.
Eye Contact:	Vapors slightly uncomfortable. Overexposure may result in severe eye injury with corneal or conjunctival inflammation on contact with the liquid.
Skin Contact:	Liquid contact may remove natural skin oils resulting in skin irritation. Dermatitis may occur with prolonged contact.
Ingestion:	May cause nausea, vomiting, diarrhea and mental sluggishness.

Chronic (long-term) effects: None known to humans

Toxicity:	LD₅₀	LC₅₀
Methyl Methacrylate Monomer (MMA)	Oral: 7900 mg/kg (rat), Dermal: >35000 mg/kg (rabbit)	Inhalation: 3 hrs. 7093 PPM (rat)
Benzoyl Peroxide	Oral: 6400 mg/kg (rat)	Oral: 2 mg/l 96 hours (guppy)

Reproductive Effects	Teratogenicity	Mutagenicity	Embryotoxicity	Sensitization to Product	Synergistic Products
Not Established	Not Established	Not Established	Not Established	Not Established	Not Established

SECTION 12 - ECOLOGICAL INFORMATION

Ecotoxicity:	None known
Mobility:	In normal use, emission of volatile organic compounds (VOC's) to the air takes place, typically at a rate of ≤50 g/l
Degradability:	Not Established
Bioaccumulation:	Not Established

SECTION 13 - WASTE DISPOSAL CONSIDERATIONS

Follow local and national regulations. Consult local disposal expert.

SECTION 14 - TRANSPORT INFORMATION

Proper Shipping Name:	Adhesives
Hazard Class:	3
Secondary Risk	None
Identification Number:	UN 1133
Packing Group:	PG II
Label Required:	Class 3 Flammable Liquid
Marine Pollutant:	NO

EXCEPTION for Ground Shipping

DOT Limited Quantity: Up to 5L per inner packaging, 30 kg gross weight per package.
Consumer Commodity: Depending on packaging, these quantities may qualify under DOT as "ORM-D".

TDG INFORMATION

TDG CLASS:	FLAMMABLE LIQUID 3
SHIPPING NAME:	ADHESIVES
UN NUMBER/PACKING GROUP:	UN 1133, PG II

SECTION 15 - REGULATORY INFORMATION

Precautionary Label Information:	Highly Flammable, Harmful	Ingredient Listings:	USA TSCA, Europe EINECS, Canada DSL, Australia AICS, Korea ECL/TCCL, Japan MITI (ENCS)
Symbols:	F, Xn		
Risk Phrases:	R-11 Highly Flammable R-20 Harmful by inhalation R-21 Harmful if contact with skin R-22 Harmful if swallowed	R-36/37/38 Irritating to eyes, respiratory system and skin R-43 May cause sensitization by skin contact.	
Safety Phrases:	S-2 Keep out of reach of children S-7 Keep container tightly closed when not in use S-9 Keep container in a well-ventilated place S-15/16 Keep away from heat and sources of ignition. No smoking S-23 Do not breathe vapor	S-24/25 Avoid contact with skin and eyes. S-29 Do not empty into drains S-37 Wear suitable gloves S-51 Use only in well ventilated areas	

SECTION 16 - OTHER INFORMATION

Specification Information:		
Department issuing data sheet:	IPS, Safety Health & Environmental Affairs	All ingredients are compliant with the requirements of the European Directive on RoHS (Restriction of Hazardous Substances).
E-mail address:	<EHSinfo@ipscorp.com>	
Training necessary:	Yes, training in practices and procedures contained in product literature.	
Reissue date / reason for reissue:	8/25/2010 Modified GHS Standard Format	
Intended Use of Product:	Two component adhesive for bonding acrylic thermoplastic sheet and other composites.	

This product is intended for use by skilled individuals at their own risk. The information contained herein is based on data considered accurate based on current state of knowledge and experience. However, no warranty is expressed or implied regarding the accuracy of this data or the results to be obtained from the use thereof.

Seam-It Applicator Gun Options:

Pro-Grade DM-200 Manual



10 to 1 ratio dispensing gun for 250ml *Seam-It* solid surface glue cartridges.

Lightweight cast Aluminum and molded plastic construction.

Standard Grade M200XMR



10 to 1 ratio dispensing gun for 250ml *Seam-It* solid surface glue cartridges.

Made in England

RTV 4500 (ACETOXY) HIGH STRENGTH

Chemical Concepts

1- Part Industrial / Construction
Grade Silicone Sealant

Our customers stick with US!

Toll Free: 800 220 1966

SPECIFIC APPLICATIONS

Making formed-in-place gaskets for compressors, gearboxes, pumps; sealing flashes, vents, flues, gutters, interior wall surfaces, marine cabins and doors, sheet metal stacks, ductwork, bonding appliance parts, and sign letters; adhering auto trim, appliance trim and name plates.

PHYSICAL PROPERTIES

Cure System	Acetoxy
Physical Properties (cured)	Rubber
Specific Gravity	1.04
Extrusion Rate, g/min.	400
Temperature Range	- 62... to 400... F
Intermittent Temperature Range	450... F
Skin Over Time (min)	10 *
Tack Over Time (min)	20 *
Cure Time (hours)	24
Tensile Strength (psi)	310
Elongation %	500
Durometer Shore A	26
Dielectric Strength kv/mm (v/mil)	20 (500)
Dielectric Constant at Hz	2.7 @ 96
Shelf Life (months)	12

* All properties derived from lab conditions, (77... F at 50% relative humidity)

MEETS SPECIFICATIONS: ASTM C-920 Type S, NS Class 25, FDA, USDA
TT-S-001543A, TT-S-00230C, NSF 51,
MIL-A-46106
UL File No. (E163851) (E255646)
(Type KEG 4200)

AVAILABLE COLORS: Clear, White, Black, Aluminum, Almond,
Bronze, Gray.
(Custom Colors Available Upon Request)

PACKAGING: 2.8 fl. oz. tubes
10.3 fl. oz. cartridges
5 gallon pails
55 gallon drums
Custom packaging



High Performance Sealant

- 100% Silicone (Acetoxy)
- Permanent Flexibility
- Excellent Weatherability, Long Life
- Warning: Not Paintable
- Temperature Use Range:
-62° F to 500° F continuous
-62° F to 650° F intermittent

Meets Specifications:

FDA CFR, 177.2600
MIL-A-46106
USDA Rating P-1
ASTM-C920 - Type S, NS,
Class 25
TT-S-001543A (COM-NBS)
TT-S-00230C (COM-NBS)
UL - UL File No. (E163851)
(E40195) (Type 5002)
Certified to NSF / ANSI STD.51.

NET 10.3 U.S. FL. OZ. (305 ml.)



Phone: 267 684 1038 • Fax: 215 357 2754

410 Pike Road • Huntingdon Valley, PA 19006

e-mail: sales@chemical-concepts.com • www.chemical-concepts.com



MATERIAL SAFETY DATA SHEET

**Chem-set™ RTV 4500 Silicone
(CLEAR)**

1. IDENTIFICATION OF THE SUBSTANCE AND OF THE COMPANY

Chemical Concepts, Inc.
410 Pike Road
Huntingdon Valley, PA 19006

Phone: 267 684 1038
Fax: 215 357 2754

FOR CHEMICAL EMERGENCIES PLEASE CONTACT: 1-800-535-5053

Revision Date: 10/01/06
General Description: Silicone elastomer
Physical Form: Paste
Color: Colorless
Odor: Acetic acid odor

NFPA PROFILE: Health - 2 Flammability - 1 Instability/Reactivity - 0

Note: NFPA = National Fire Protection Association

2. OSHA HAZARDOUS COMPONENTS

CAS Number	Wt %	Component Name
4253-34-3	1.0 – 5.0	Methyltriacetoxysilane
17689-77-9	1.0 – 5.0	Ethyltriacetoxysilane

The above components are hazardous as defined in 29 CFR 1910.1200.

3. EFFECTS OF OVEREXPOSURE

Accute Effects:

Eye: Direct contact may cause moderate irritation.
Skin: May cause moderate irritation
Inhalation: Irritates respiratory passages very slightly
Oral: Low ingestion hazard in normal use.

Prolonged / Repeated Exposure Effects

Skin: No Known applicable information.
Inhalation: No Known applicable information.
Oral: No Known applicable information.

Signs and Symptoms of Overexposure

No Known applicable information.

Medical Conditions Aggravated by Exposure

No Known applicable information.

The above listed potential effects of overexposure are based on actual data, results of studies performed upon similar compositions, component data and / or expert review of the product. Please refer to Section 11 for the detailed toxicology information.

4. FIRST AID MEASURES

Eye: Immediately flush with water for 15 minutes. Get medical attention.
Skin: Remove from skin and wash thoroughly with soap and water or waterless cleanser. Get medical attention if irritation or other ill effects develop or persist.
Inhalation: No first aid should be needed.
Oral: No first aid is needed.
Comments: Treat according to persons condition and specifics of exposure.

5. FIRE FIGHTING MEASURES

Flash Point: Not applicable
Autoignition Temperature: Not determined
Flammability Limits in Air: Not determined
Extinguishing Media: On large scale fires use dry chemical foam or water spray. On small fires use carbon dioxide (CO₂), dry chemical or water spray. Water can be used to cool fire exposed containers.
Fire Fighting Measures: Self contained breathing apparatus and protective clothing should be worn in fighting large fires involving chemicals. Determine the need to evacuate or isolate the area according to your local emergency plan. Use water spray to keep fire exposed containers cool.
Usual Fire Hazards: None.

Hazardous Decomposition Products

Thermal breakdown of this product during fire or very high heat conditions may evolve the following hazardous decomposition products. Carbon oxides and traces of incompletely burned carbon compounds. Formaldehyde. Silicon dioxide.

6. ACCIDENTAL RELEASE MEASURES

Containment / Clean up: Observe all personal protection equipment recommendations described in section 5 and 8. Wipe up or scrape up and contain for salvage or disposal. Clean area as appropriate since some silicone materials, even in small quantities, may present a slip hazard. Final cleaning may require use of steam, solvents or detergents. Dispose of saturated absorbent or cleaning materials appropriately, since spontaneous heating may occur. Local, state, and federal laws and regulations may apply to releases and disposal of this material, as well as those materials and items employed in the cleanup of releases. You will need to determine which federal, state, and local laws and regulations are applicable. Section 13 and 15 of this MSDS provide information regarding certain federal and state requirements.

Note: See section 8 for Personal Protective Equipment for Spills. Call Chemical Concepts @ 1.800.220.1966, if additional information is required.

7. HANDLING AND STORAGE

Use with adequate ventilation. Product evolves acetic acid (HOAc) when exposed to water or humid air. Provide ventilation during use to control HOAc within exposure guidelines or use respiratory protection. Avoid eye contact. Avoid skin contact.

Use reasonable care and store away from oxidizing materials. Keep container closed and store away from water or moisture.

8. EXPOSURE CONTROLS / PERSONAL PROTECTION

Component Exposure Limits

CAS Number	Component Name	Exposure Limits
4253-34-3	Methytriacetoxysilane	See acetic acid comments
17689-77-9	Ethyltriacetoxysilane	See acetic acid comments

Acetic acid is formed upon contact with water or humid air. Provide adequate ventilation to control exposures within guidelines of OSHA PEL: TWA 10 ppm and ACGIH TLV: TWA 10 ppm. STEL 15 ppm.

Engineering Controls

Local Ventilation: Recommended
General Ventilation: Recommended

Personal Protective Equipment for Routine Handling

Eyes: Use proper protection – safety glasses as a minimum
Skin: Wash at mealtime and end of shift. Contaminated clothing and shoes should be removed as soon as practical and thoroughly cleaned before reuse. Chemical protective gloves are recommended.
Suitable Gloves: Silver Shield ® 4H®.
Inhalation: No respiratory protection should be needed.
Suitable Respirator: None should be needed.

Personal Protective Equipment for Spills.

Eyes: Use proper protection – safety glasses as a minimum.
Skin: Wash at mealtime and end of shift. Contaminated clothing and shoes should be removed as soon as practical and thoroughly cleaned before reuse. Chemical protective gloves are recommended.

Inhalation / Suitable Respirator: No respiratory protection needed.

Precautionary Measures: Avoid eye contact. Avoid skin contact. Use reasonable care.

Comments: Product evolves acetic acid (HOAc) when exposed to water or humid air. Provide ventilation during use to control HOAc within exposure guidelines or use respiratory protection.

When heated to temperatures above 150 degrees C in the presence of air, product can form formaldehyde vapors. Formaldehyde is a potential cancer hazard, a known skin and respiratory sensitizer, and an irritant to the eyes, nose, throat, skin, and digestive system. Safe handling conditions may be maintained by keeping vapor concentrations within the OSHA Permissible Exposure Limit for Formaldehyde.

Note: These precautions are for room temperature handling. Use at elevated temperature or aerosol / spray applications may require added precautions.

9. PHYSICAL AND CHEMICAL PROPERTIES

Physical Form:	Paste
Color:	Colorless
Odor:	Acetic Acid odor
Specific Gravity @ 25 C:	1.032
Viscosity:	Not determined
Freezing / Melting Point:	Not determined
Boiling Point:	Not determined
Vapor Pressure @ 25C:	Not determined
Solubility in Water:	Not determined
PH:	Not determined
Volatile Content:	Not determined

Note: The above information is not intended for use in preparing product specifications. Contact Dow Corning before writing specifications.

10. STABILITY AND REACTIVITY

Chemical Stability:	Stable.
Hazardous Polymerization:	Hazardous polymerization will not occur.
Conditions to Avoid;	None
Material to Avoid:	Oxidizing material can cause a reaction. Water, moisture, or humid air can cause hazardous vapors to form as described in section 8.

11. TOXICOLOGICAL INFORMATION

Special Hazard Information on Components

No known applicable information.

12. ECOLOGICAL INFORMATION

Environmental Fate and Distribution

Complete information is not yet available.

Environmental Effects

Complete information is not yet available.

Fate and Effects in Waste Water Treatment Plants

Complete information is not yet available

Ecotoxicity Classification Criteria

Hazard Parameters (LC50 or EC 50)	High	Medium	Low
Acute Aquatic Toxicity (mg/L)	<=1	>1 and <=100	>100
Acute Terrestrial Toxicity	<= 100	> 100 and <= 2000	>2000

! This table is adapted from "Environmental Toxicology and Risk Assessment". ASTM STP 1179, p34, 1993.

This table can be used to classify the ecotoxicity of this product when ecotoxicity data is listed above. Please read the other information presented in the section concerning the overall ecological safety of this material.

13. DISPOSAL CONSIDERATIONS

RCRA Hazard Class (40 – CFR 261)

When a decision is made to discard this material, as received, is it classified as a hazardous waste? No

State or local laws may impose additional regulatory requirements regarding disposal.

Call Chemical Concepts at 1.800.220.1966, if additional information is required.

14. TRANSPORT INFORMATION

DOT Road Shipment Information (49 CFR 172.101)

Not subject to DOT

Ocean shipment (IMDG)

Not subject to IMDG code.

Air Shipment (IATA)

Not subject to IATA regulations.

Call Chemical Concepts, Inc, if additional information is required.

15. REGULATORY INFORMATION

Contents of this MSDS comply with the OSHA Hazard Communication Standard 29 CFR 1910.1200.

TSCA Status: All chemical substances in this material are included on or exempted from listing on the TSCA Inventory of chemical Substances.

EPA SARA Title III Chemical Listings

Section 302 Extremely Hazardous Substances: None

Section 304 CERCLA Hazardous Substances: None

Section 312 Hazard Class:

Acute:	Yes
Chronic:	No
Fire:	No
Pressure:	No
Reactive:	No

Section 313 Toxic Chemicals: None present or none present in regulated quantities.

Supplemental State Compliance Information

California

Warning: this product contains the following chemicals listed by the state of California under the safe Drinking Water and toxic Enforcement Act of 1986 (Proposition 65) as being known to cause cancer, birth defects or other reproductive harm.

None known.

Massachusetts

CAS Number	Wt %	Component Name
7631-86-9	< = 10.0	Silica, amorphous

New Jersey

CAS Number	Wt%	Component Name
70131-67-8	< = 87.0	Dimethyl siloxane, hydroxy terminated
7631-86-9	< = 10.0	Silica, amorphous
4253-34-3	1.0 – 5.0	Methyltriacetoxysilane
17689-77-9	1.0 – 5.0	Ethyltriacetoxysilane

Pennsylvania

CAS Number	Wt%	Component Name
70131-67-8	< = 87.0	Dimethyl siloxane, hydroxy-terminated
7631-86-9	< = 10.0	Silica, Amorphous

16. OTHER INFORMATION

Prepared By: Chemical Concepts, Inc.

These data are offered in good faith as typical values and not as product specification. No warranty, either expressed or implied, is hereby made. The recommended industrial hygiene and safe handling procedures are believed to be generally applicable. However, each user should review these recommendations in the specific context of the intended use and determine whether they are appropriate.

****** END OF MSDS ******