

JOB NAME _____
 ARCHITECT _____
 ENGINEER _____
 CONTRACTOR _____
 LOCATION _____

SUBMITTAL SHEET
 Form Number GS0206.2 Effective Date 8/99
 Replaces GS0206.1



EGC10 SERIES

Eggcrate Grille, 1" x 1" x 1" grid

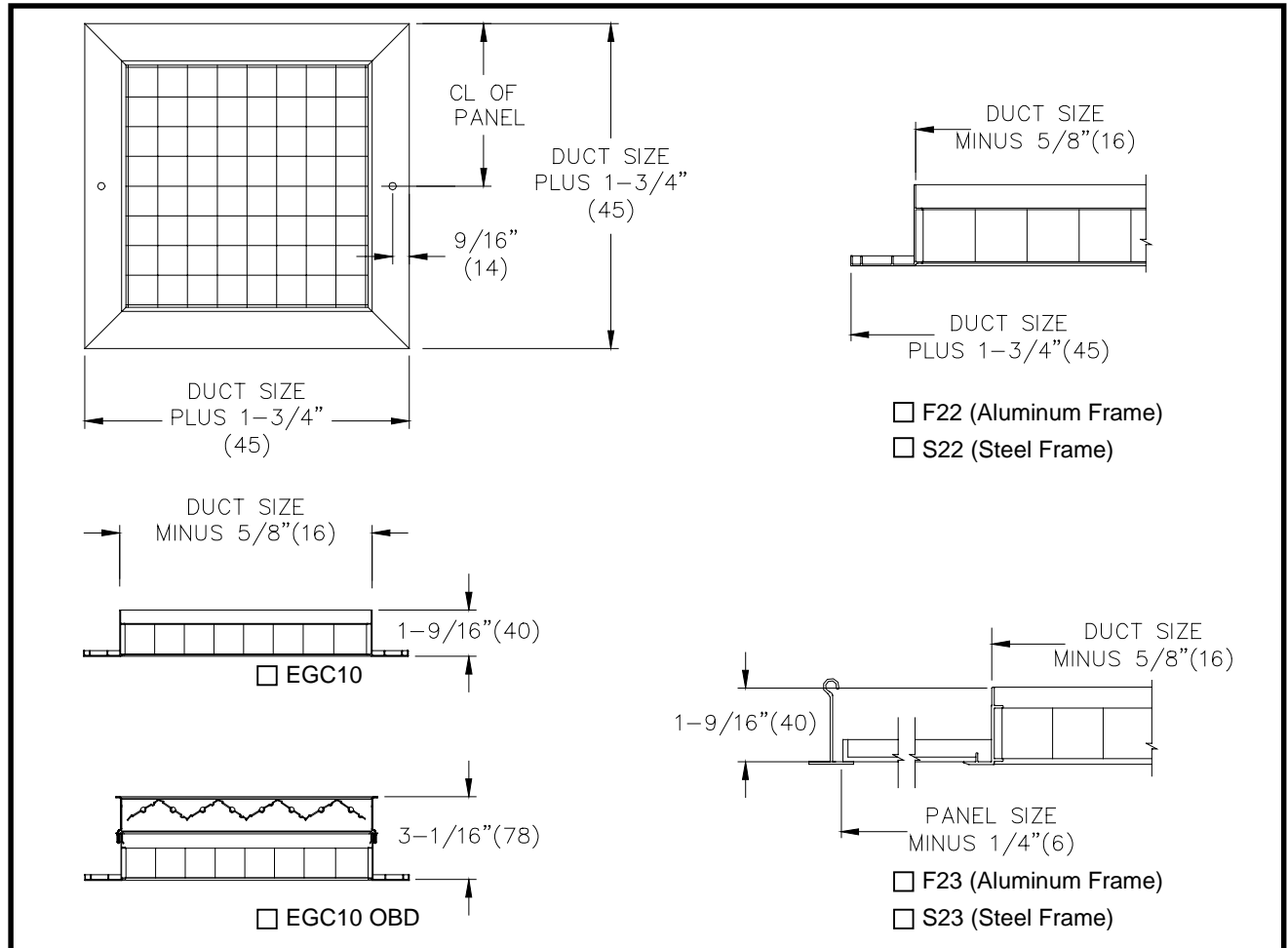

NOTES:

1. Frame 22 shown. See frame style detail for frame dimensions.
2. Aluminum Eggcrate Core.
3. Standard finish 44 British white.
4. Dimensions are in inches.
5. Dimension in parenthesis are in mm.
6. Available neck size 6 x 6, to 48 x 48.
7. Egg Crate dimensions 1" x 1" x 1" (25 x 25 x 25).

ACCESSORIES:

- Steel opposed blade damper - Model OBD
- Aluminum opposed blade damper - Model 5OBD

STD PANEL SIZES:
12" x 12" (305 x 305)
24" x 12" (610 x 305)
24" x 24" (610 x 610)
48" x 24" (1219 x 610)
48" x 48" (1219 x 1219)